

LOWER CHIWAWA RIVER PROJECT AREA G - PHASE 2: LARGE WOOD ENHANCEMENT LOWER CHIWAWA RIVER ASSESSMENT UNIT WENATCHEE RIVER SUB-BASIN, WASHINGTON DRAFT FINAL DESIGN DRAWINGS

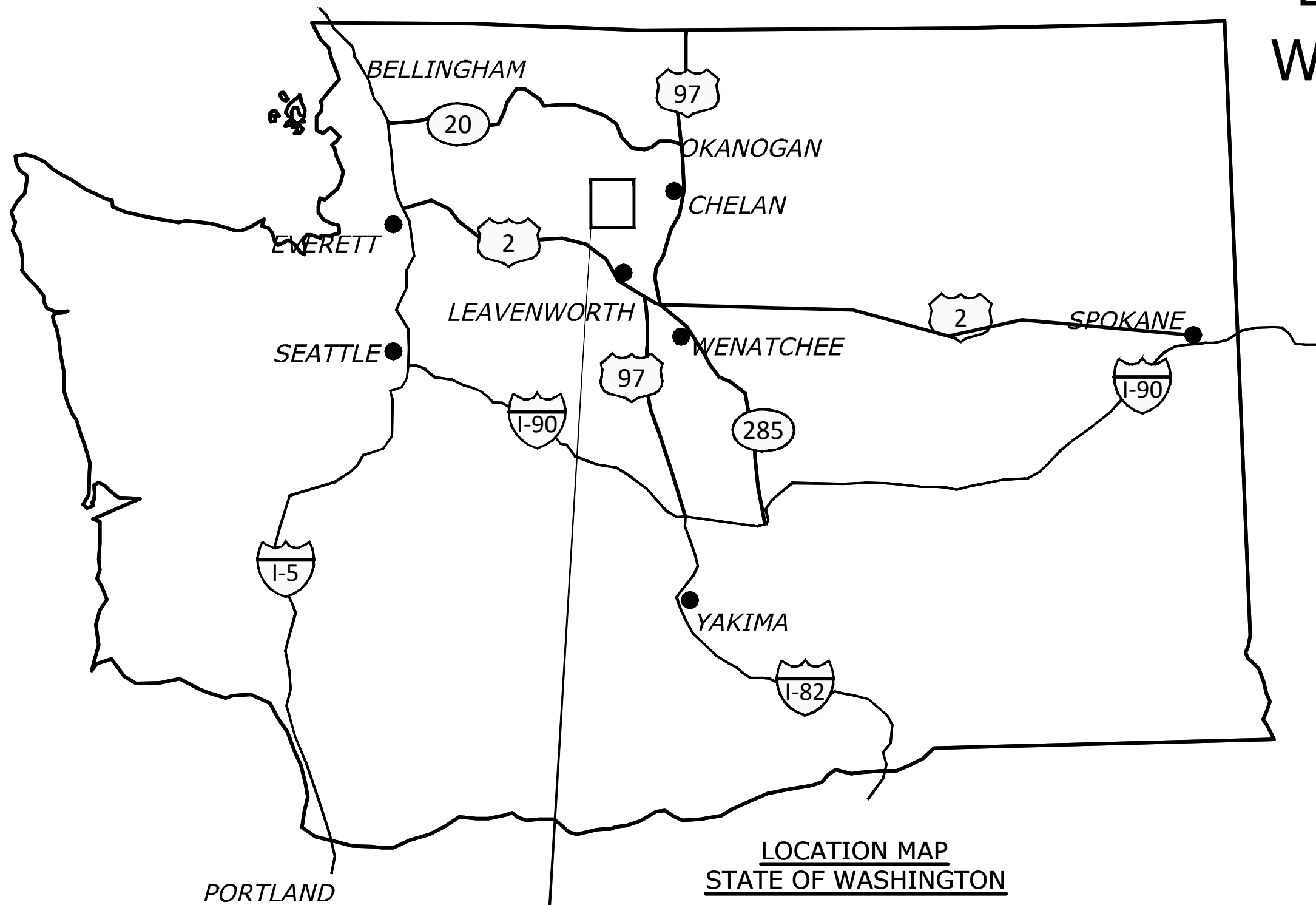

501 Portway Avenue, Suite 101
Hood River, OR 97031
541.386.9003
www.interfluve.com



LOCATION MAP
STATE OF WASHINGTON
NOT TO SCALE



VICINITY MAP
NOT TO SCALE

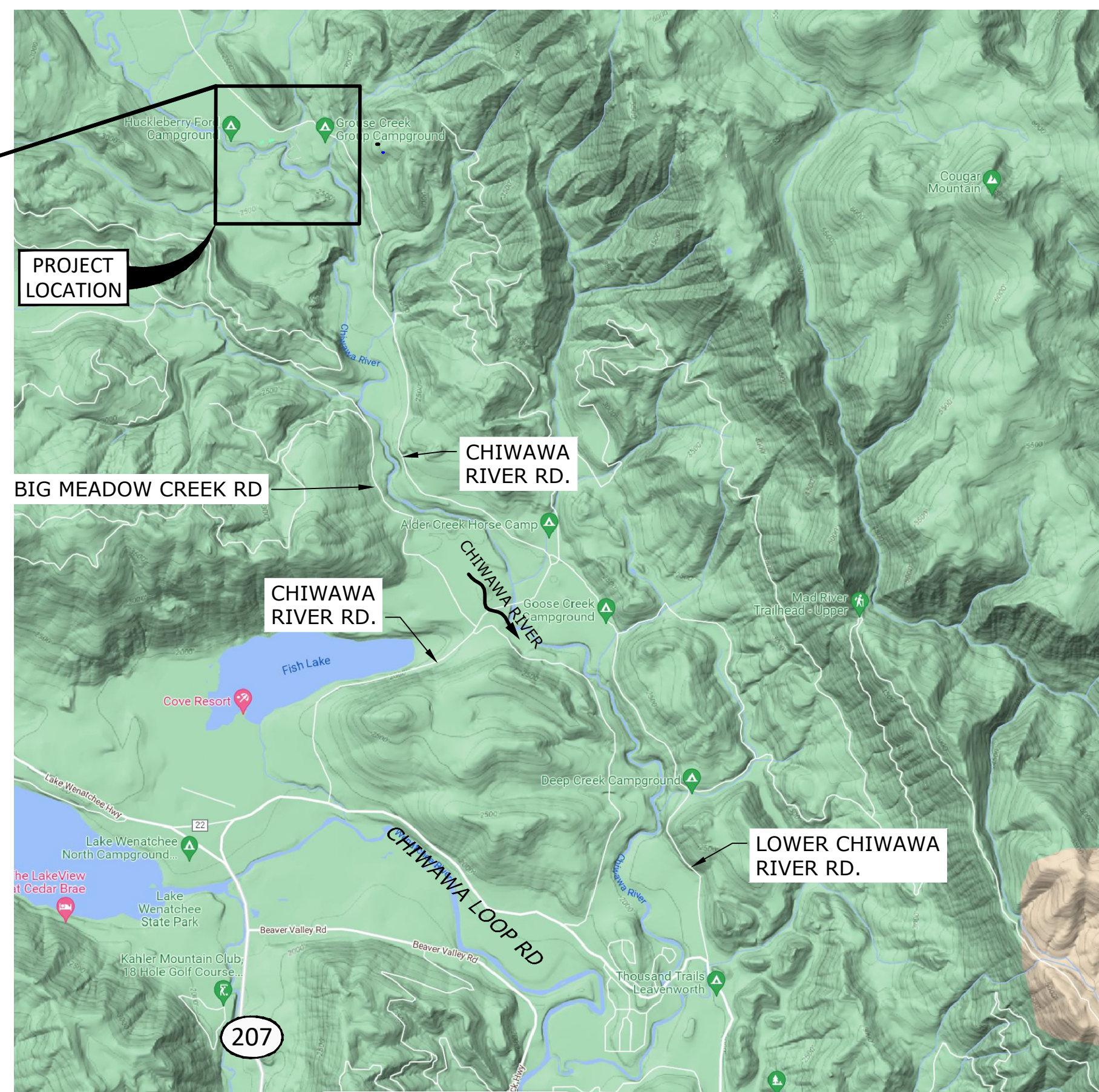

PROJECT LOCATION MAP
SCALE 1" = 5000'

Sheet List Table	
Sheet Number	Sheet Title
1	COVER SHEET
2	GENERAL NOTES
3	GENERAL CONSERVATION MEASURES (1 OF 3)
4	GENERAL CONSERVATION MEASURES (2 OF 3)
5	GENERAL CONSERVATION MEASURES (3 OF 3)
6	TEMPORARY COFFERDAM DETAIL
7	EXISTING CONDITIONS, SITE ACCESS AND STAGING
8	SITE OVERVIEW AND SHEET INDEX
9	PROPOSED CONDITIONS
10	BANK BURRIED CROSS SECTIONS
11	APEX SECTION AND PROFILE
12	TYPICAL DETAILS (1 OF 4)
13	TYPICAL DETAILS (2 OF 4)
14	TYPICAL DETAILS (3 OF 4)
15	TYPICAL DETAILS (4 OF 4)

PREPARED FOR:
YAKAMA NATION FISHERIES
2 JOHNSON LANE
WINTHROP WA, 98862

PREPARED BY:
INTER-FLUVE
501 PORTWAY AVE, SUITE 101
HOOD RIVER, OR 97031

U.S. DEPARTMENT OF THE INTERIOR
BUREAU OF RECLAMATION,
PACIFIC NORTHWEST REGION
CONTACT: STEVE KOLK, P.E.
1150 N. CURTIS RD.
BOISE, ID 83706



ALWAYS THINK SAFETY

U.S. DEPARTMENT OF THE INTERIOR
BUREAU OF RECLAMATION
COLUMBIA PACIFIC NORTHWEST REGION
FCRPS HABITAT IMPROVEMENT PROGRAM
LOWER CHIWAWA RIVER PROJECT
PROJECT AREA G - PHASE 2
DRAFT FINAL DESIGN

DRAFT

CM
DRAWN
LS, PB
ACCEPTED
BOISE, ID APRIL 27, 2026

COVER SHEET
SHEET 1

CAD SYSTEM
AutoCAD 2015 (LMS TECH)
LAST SAVED DATE
2026-04-29
LAST SAVED BY
CIRCONELL
JFL LOWER CHIWAWA AREA_G.DWG

EXISTING DATA

TOPOGRAPHY AND BATHYMETRY WAS COLLECTED ON AUGUST 3RD AND 4TH, 2021 BY NV5G USING RED/GREEN LIDAR. AS DOCUMENTED IN THE REPORT: NV5, GEOSPATIAL, OCTOBER 5, 2021. CHIWAHA RIVER, WASHINGTON. TOPOBATHYMETRIC LIDAR TECHNICAL DATA REPORT. DATA SOLICITED BY INTER-FLUVE DELIVERED BY: NV5 GEOSPATIAL. CERTIFIED BY: VON PETER SILVIA, PLS NO. 53957.

AERIAL IMAGERY COLLECTED AUGUST 3-5, 2021 BY NV5.

WETLANDS AND WATERS OF THE US

ORDINARY HIGH WATER DEPICTED ON THESE PLANS IS BASED ON HYDRAULIC MODEL RESULTS FOR THE 2-YEAR FLOOD.

WETLANDS DEPICTED ON THESE PLANS WERE DELINEATED BY HAMER ENVIRONMENTAL IN 2025

SOILS

SOILS AT THE SITE ARE EXPECTED TO CONSIST OF LOWER CHIWAHA RIVER ALLUVIUM (BOULDERS/COBBLES/GRAVELS) AND FLOODPLAIN SOILS (SILT/SAND WITH COBBLES AND GRAVELS). CHORALMONT CINDERY SANDY LOAM IN THE OVERBANK AND UPLAND AREAS, PER NRCS WEB SOIL SURVEY (https://websoilsurvey.nrcs.usda.gov/app/WebSoilSurvey.aspx)

UTILITIES

THE CONTRACTOR SHALL BE SOLELY RESPONSIBLE FOR HAVING UTILITIES LOCATED PRIOR TO CONSTRUCTION ACTIVITIES. THE CONTRACTOR SHALL CALL (800-424-5555) FOR UTILITY LOCATE PRIOR TO CONSTRUCTION. THE CONTRACTOR SHALL IMMEDIATELY CONTACT THE EFFECTED UTILITY SERVICE TO REPORT ANY DAMAGED OR DESTROYED UTILITIES. THE CONTRACTOR SHALL PROVIDE EQUIPMENT AND LABOR TO AID THE EFFECTED UTILITY SERVICE IN REPAIRING DAMAGED OR DESTROYED UTILITIES AT NO ADDITIONAL COST TO OWNER OR PROJECT SPONSOR.

EROSION CONTROL

CONTRACTOR SHALL BE SOLELY RESPONSIBLE, AT OWN EXPENSE, FOR PROVIDING AND MAINTAINING ALL NECESSARY EROSION CONTROL FACILITIES TO COMPLY WITH APPLICABLE EROSION CONTROL REGULATIONS, PERMIT CONDITIONS AND THE APPROVED TESC PLAN IN ACCORDANCE WITH THE SPECIFICATIONS. SEE GENERAL AQUATIC CONSERVATION MEASURES ON SHEETS 3-5 FOR ADDITIONAL REQUIREMENTS.

FISH SALVAGE

FISH SALVAGE SHALL BE COMPLETED BY EXPERIENCED FISH BIOLOGIST AND COORDINATED WITH OWNER. SEE GENERAL AQUATIC CONSERVATION MEASURES ON SHEETS 3-5 AND THE SPECIFICATIONS FOR ADDITIONAL REQUIREMENTS.

CULTURAL RESOURCES

A YAKAMA NATION ARCHEOLOGIST WILL BE ON SITE DURING CONSTRUCTION. ENCOUNTERING THE FOLLOWING CULTURAL RESOURCES REQUIRES THE IMMEDIATE DISCONTINUATION OF ALL GROUND-DISTURBING ACTIVITY:

- NATIVE AMERICAN CULTURAL ARTIFACTS (EXAMPLE: FLAKES, ARROWHEADS, STONE TOOLS, BONE TOOLS, POTTERY, ETC.)
-HISTORIC ERA ARTIFACTS (EXAMPLE: BUILDING FOUNDATIONS, HOMESTEADS, SHIPWRECKS, MINING CAMPS, ETC.)
-HUMAN SKELETAL REMAINS AND BONE FRAGMENTS

DO NOT TOUCH OR MOVE THE OBJECTS AND MAINTAIN THE CONFIDENTIALITY OF THE SITE. FOLLOW THE PROCEDURES LISTED IN THE FOREST SERVICE INADVERTENT DISCOVERY PROCEDURE AND AWAIT FURTHER DIRECTION FROM THE ARCHEOLOGIST AND FOREST SERVICE'S CULTURAL RESOURCES STAFF.

CONSTRUCTION PLANS AND SPECIFICATIONS

ALL WORK SHALL CONFORM TO THE CURRENT EDITIONS OF STANDARD PLANS AND SPECIFICATIONS OF THE WASHINGTON STATE DEPARTMENT OF TRANSPORTATION (WSDOT), AND LOCAL STANDARDS UNLESS INDICATED OTHERWISE BY THE CONTRACT DOCUMENTS.

IN CASE OF A CONFLICT BETWEEN REGULATORY STANDARDS, LOCAL REGULATIONS, OR OTHER CONTRACT DOCUMENTATION, THE MORE STRINGENT SHALL PREVAIL, UNLESS OTHERWISE SPECIFIED IN WRITING BY THE OWNER

CONSTRUCTION STAKING

THE OWNERS REPRESENTATIVE WILL FLAG OR MARK LARGE WOOD STRUCTURE LOCATIONS AND APPROXIMATE EXTENTS. SOME FIELD ADJUSTMENTS TO THE LINES AND GRADES ARE TO BE EXPECTED.

CONTRACTOR SHALL MEET WITH THE OWNER TO DEFINE AND MARK ACCESS ROUTES AND LIMITS OF DISTURBANCE PRIOR TO MOBILIZATION OF EQUIPMENT OR MATERIALS ONTO THE SITE.

THE CONTRACTOR SHALL REPLACE DAMAGED OR DESTROYED CONSTRUCTION STAKES AT NO ADDITIONAL COST TO OWNER OR PROJECT SPONSOR.

CONSTRUCTION ACCESS

THE CONTRACTOR IS SOLELY RESPONSIBLE FOR PROVIDING ANY REQUIRED TRAFFIC CONTROL INCLUDING, BUT NOT LIMITED TO, SIGNAGE AND FLAGGERS; AND FOR OBTAINING ANY REQUIRED ACCESS PERMITS.

FOR DURATION OF PROJECT, CONTRACTOR SHALL KEEP ALL PRIVATE AND PUBLIC ROADS USED FOR ACCESS FREE OF DEBRIS AND MUD.

TREE SALVAGE

ALL TREES TO BE REMOVED SHALL BE APPROVED AND CLEARLY MARKED BY THE OWNER'S REPRESENTATIVE.

ALL REMOVED NON-INVASIVE VEGETATION SHALL BE INCORPORATED INTO LARGE WOOD STRUCTURES IN ACCORDANCE WITH THE SPECIFICATIONS. IF EXCESS MATERIAL NEEDS DISPOSAL OUTSIDE OF CHANNEL WORK, IT SHALL BE DISTRIBUTED ON THE FLOODPLAIN AS DIRECTED BY THE OWNER'S REPRESENTATIVE.

ALL TREES REMOVED WITHIN CLEARING LIMITS, UNLESS OTHERWISE NOTED, SHALL BE REMOVED IN ACCORDANCE WITH THE SPECIFICATIONS.

LIVE TREES

ALL TREES NOT MARKED FOR REMOVAL SHALL BE PRESERVED AND UNDISTURBED. CONSTRUCTION ACTIVITY SHALL NOT DEBARK OR DAMAGE LIVE TREES.

KEEP OUT OF DRIP LINE OF ALL EXISTING MATURE TREES NOT MARKED FOR REMOVAL.

ANY TREES MARKED FOR REMOVAL SHALL BE REMOVED IN ACCORDANCE WITH THE SPECIFICATIONS.

ESTIMATE OF CONSTRUCTION QUANTITIES table with columns: ROOTWAD LOGS, PILES, SALVAGED TREES, SLASH and values: 260, 120, 70, 550 CY

ESTIMATED CONSTRUCTION QUANTITIES table with columns: LARGE WOOD STRUCTURE, ROOTWAD LOGS, VERTICAL LOGS, SALVAGED TREES, SLASH, POOL EXCAVATION, TEMPORARY CUT/FILL, TEMPORARY COFFER DAM and values: 20, 10, 2, 30, 100, 175, 100, 20, 0, 2, 30, 100, 280, 85, 20, 10, 2, 30, 100, 110, 35, 20, 0, 2, 30, 100, 310, 85, 20, 10, 2, 30, 100, 165, 100, 40, 24, 15, 100, 300, 450, 215, 40, 22, 15, 100, 300, 710, 205, 40, 22, 15, 100, 300, 620, 220, 40, 22, 15, 100, 300, 420, 220, TOTAL, 260, 120, 70, 550, 1700, 3240, 1265

ABBREVIATIONS

- ° DEGREE
' FEET
" INCH
% PERCENT
APPROX. APPROXIMATE
CON'T CONTINUED
CY. CUBIC YARD
DIA. DIAMETER
DBH DIAMETER AT BREAST HEIGHT
D.S. DOWNSTREAM
ELEV ELEVATION
ESC EROSION SEDIMENT AND CONTROL
EXIST EXISTING
FT FEET
IN INCH
INV INVERT
LF LINIER FOOT
LLC LIMITED LIABILITY COMPANY
LWM LARGE WOODY MATERIAL
LWS LARGE WOOD STRUCTURE
MAX MAXIMUM
MIN MINIMUM
NO. NUMBER
OHW ORDINARY HIGH WATER
RD ROAD
SF SQUARE FEET
SIM SIMILAR
STA STATION
TESC TEMPORARY EROSION AND SEDIMENT CONTROL
TYP TYPICAL
U.S. UPSTREAM
WA WASHINGTON
YR YEAR



ALWAYS THINK SAFETY

U.S. DEPARTMENT OF THE INTERIOR
BUREAU OF RECLAMATION
COLUMBIA PACIFIC NORTHWEST REGION
FCRPS HABITAT IMPROVEMENT PROGRAM
LOWER CHIWAHA RIVER PROJECT
PROJECT AREA G - PHASE 2
DRAFT FINAL DESIGN

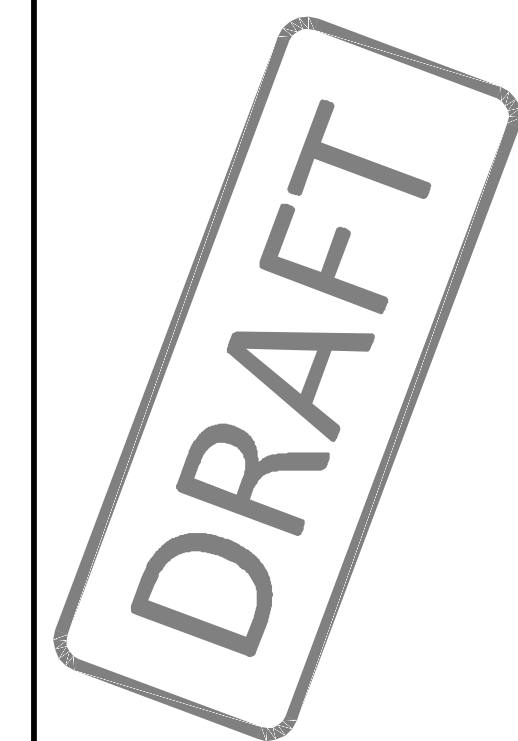

CM DRAWN
LS, PB ACCEPTED
BOISE, ID APRIL 27, 2026

GENERAL NOTES

SHEET 2

SHEET 2 OF 15

LAST SAVED DATE 2026-04-29 LAC SAVED BY GREGG WELLS

CAD SYSTEM AutoCAD 2015 (LMS TECH) PLOTTER HP DesignJet 500 Plotter JFL LOWERCHIWAHA_AREA_G.DWG

GENERAL CONSERVATION MEASURES APPLICABLE TO ALL ACTIONS

THE ACTIVITIES COVERED UNDER ARBO ARE INTENDED TO PROTECT AND RESTORE FISH AND WILDLIFE HABITAT WITH LONG-TERM BENEFITS TO ESA-LISTED SPECIES. THE FOLLOWING GENERAL CONSERVATION MEASURES (DEVELOPED IN COORDINATION WITH USFWS, NMFS AND ADAPTED FROM THE HIP GENERAL CONSERVATION MEASURES.) WILL BE APPLIED TO ALL ACTIONS OF THIS PROJECT.

PROJECT DESIGN AND SITE PREPARATION

1. STATE AND FEDERAL PERMITS

- A. ALL APPLICABLE REGULATORY PERMITS AND OFFICIAL PROJECT AUTHORIZATIONS WILL BE OBTAINED BEFORE PROJECT IMPLEMENTATION.
- B. THESE PERMITS AND AUTHORIZATIONS INCLUDE, BUT ARE NOT LIMITED TO, NATIONAL ENVIRONMENTAL POLICY ACT, NATIONAL HISTORIC PRESERVATION ACT, THE APPROPRIATE STATE AGENCY REMOVAL AND FILL PERMIT, USACE CLEAN WATER ACT (CWA) 404 PERMITS, AND CWA SECTION 401 WATER QUALITY CERTIFICATIONS.

2. TIMING OF IN-WATER WORK

- A. APPROPRIATE STATE (OREGON DEPARTMENT OF FISH AND WILDLIFE (ODFW), WASHINGTON DEPARTMENT OF FISH AND WILDLIFE (WDFW), IDAHO DEPARTMENT OF FISH AND GAME (IDFG), AND MONTANA FISH WILDLIFE AND PARKS (MFWP)) GUIDELINES FOR TIMING OF IN-WATER WORK WINDOWS (IWW) WILL BE FOLLOWED.
- B. CHANGES TO ESTABLISHED WORK WINDOWS WILL BE APPROVED BY REGIONAL STATE BIOLOGISTS AND REGULATORY AGENCIES.
- C. BULL TROUT. FOR AREAS WITH DESIGNATED IN-WATER WORK WINDOWS FOR BULL TROUT OR AREAS KNOWN TO HAVE BULL TROUT, PROJECT PROponents WILL CONTACT THE APPROPRIATE USFWS FIELD OFFICE TO INSURE THAT ALL REASONABLE IMPLEMENTATION MEASURES ARE CONSIDERED AND AN APPROPRIATE IN-WATER WORK WINDOW IS BEING USED TO MINIMIZE PROJECT EFFECTS.
- D. LAMPREY. WORKING IN STREAM OR RIVER CHANNELS THAT CONTAIN PACIFIC LAMPREY WILL BE AVOIDED FROM MARCH 1 TO JULY 1 FOR REACHES <5,000 FEET IN ELEVATION AND FROM MARCH 1 TO AUGUST 1 FOR REACHES >5,000 FEET. IF EITHER TIMEFRAME IS INCOMPATIBLE WITH OTHER OBJECTIVES, THE AREA WILL BE SURVEYED FOR NESTS AND LAMPREY PRESENCE, AND AVOIDED IF POSSIBLE. IF LAMPREYS ARE KNOWN TO EXIST, THE PROJECT SPONSOR WILL UTILIZE DEWATERING AND SALVAGE PROCEDURES (SEE FISH SALVAGE AND ELECTROFISHING SECTIONS) TO MINIMIZE ADVERSE EFFECTS.
- E. THE IN-WATER WORK WINDOW WILL BE JULY 1 THROUGH JULY 31.

3. CONTAMINANTS

- A. EXCAVATION OF MORE THAN 20 CUBIC YARDS WILL REQUIRE A SITE VISIT AND DOCUMENTED ASSESSMENT FOR POTENTIAL CONTAMINANT SOURCES. THE SITE ASSESSMENT WILL BE STORED WITH PROJECT FILES OR AS AN APPENDIX TO THE BASIS OF DESIGN REPORT.
- B. THE SITE ASSESSMENT WILL SUMMARIZE:
 - 1. THE SITE VISIT, CONDITION OF THE PROPERTY, AND IDENTIFICATION OF ANY AREAS USED FOR VARIOUS INDUSTRIAL PROCESSES;
 - 2. AVAILABLE RECORDS, SUCH AS FORMER SITE USE, BUILDING PLANS, AND RECORDS OF ANY PRIOR CONTAMINATION EVENTS;
 - 3. INTERVIEWS WITH KNOWLEDGEABLE PEOPLE, SUCH AS SITE OWNERS, OPERATORS, OCCUPANTS, NEIGHBORS, OR LOCAL GOVERNMENT OFFICIALS; AND
 - 4. THE TYPE, QUANTITY, AND EXTENT OF ANY POTENTIAL CONTAMINATION SOURCES.

4. SITE LAYOUT AND FLAGGING

- A. CONSTRUCTION AREAS TO BE CLEARLY FLAGGED PRIOR TO CONSTRUCTION
- B. AREAS TO BE FLAGGED WILL INCLUDE:
 - 1. SENSITIVE RESOURCE AREAS, SUCH AS AREAS BELOW ORDINARY HIGH WATER, SPAWNING AREAS, SPRINGS, AND WETLANDS;
 - 2. EQUIPMENT ENTRY AND EXIT POINTS;
 - 3. ROAD AND STREAM CROSSING ALIGNMENTS;
 - 4. STAGING, STORAGE, AND STOCKPILE AREAS; AND
 - 5. NO-SPRAY AREAS AND BUFFERS.

5. TEMPORARY ACCESS ROADS AND PATHS

- A. EXISTING ACCESS ROADS AND PATHS WILL BE PREFERENTIALLY USED WHENEVER REASONABLE, AND THE NUMBER AND LENGTH OF TEMPORARY ACCESS ROADS AND PATHS THROUGH RIPARIAN AREAS AND FLOODPLAINS WILL BE MINIMIZED.
- B. VEHICLE USE AND HUMAN ACTIVITIES, INCLUDING WALKING, IN AREAS OCCUPIED BY TERRESTRIAL ESA-LISTED SPECIES WILL BE MINIMIZED.
- C. TEMPORARY ACCESS ROADS AND PATHS WILL NOT BE BUILT ON SLOPES WHERE GRADE, SOIL, OR OTHER FEATURES SUGGEST A LIKELIHOOD OF EXCESSIVE EROSION OR FAILURE. IF SLOPES ARE STEEPER THAN 30%, THEN THE ROAD WILL BE DESIGNED BY A CIVIL ENGINEER WITH EXPERIENCE IN STEEP ROAD DESIGN.
- D. THE REMOVAL OF RIPARIAN VEGETATION DURING CONSTRUCTION OF TEMPORARY ACCESS ROADS WILL BE MINIMIZED. WHEN TEMPORARY VEGETATION REMOVAL IS REQUIRED, VEGETATION WILL BE CUT AT GROUND LEVEL (NOT GRUBBED). TREES SUITABLE FOR USE IN LARGE WOOD STRUCTURES WILL BE HARVESTED WITH ROOTS AND BRANCHES INTACT TO THE EXTENT PRACTICABLE. SOIL WILL BE REPLACED INTO THE ROOT CAVITY AND SMOOTHED TO THE NATIVE CONTOURS.
- E. AT PROJECT COMPLETION, ALL TEMPORARY ACCESS ROADS AND PATHS WILL BE OBLITERATED, AND THE SOIL WILL BE STABILIZED AND REVEGETATED. ROAD AND PATH OBLITERATION REFERS TO THE MOST COMPREHENSIVE DEGREE OF DECOMMISSIONING AND INVOLVES DECOMPACTING THE SURFACE AND DITCH, PULLING THE FILL MATERIAL ONTO THE RUNNING SURFACE, AND RESHAPING TO MATCH THE ORIGINAL CONTOUR.

6. TEMPORARY STREAM CROSSINGS

- A. EXISTING STREAM CROSSINGS OR BEDROCK WILL BE PREFERENTIALLY USED WHENEVER REASONABLE, AND THE NUMBER OF TEMPORARY STREAM CROSSINGS WILL BE MINIMIZED.
- B. TEMPORARY BRIDGES AND CULVERTS WILL BE INSTALLED TO ALLOW FOR EQUIPMENT AND VEHICLE CROSSING OVER PERENNIAL STREAMS DURING CONSTRUCTION. TREATED WOOD SHALL NOT BE USED ON TEMPORARY BRIDGE CROSSINGS OR IN LOCATIONS IN CONTACT WITH OR DIRECTLY OVER WATER.
- C. FOR PROJECTS THAT REQUIRE EQUIPMENT AND VEHICLES TO CROSS IN THE WET:
 - 1. THE LOCATION AND NUMBER OF ALL WET CROSSINGS SHALL BE APPROVED BY THE EC LEAD AND DOCUMENTED IN THE CONSTRUCTION PLANS;
 - 2. VEHICLES AND MACHINERY SHALL CROSS STREAMS AT RIGHT ANGLES TO THE MAIN CHANNEL WHENEVER POSSIBLE;
 - 3. NO STREAM CROSSINGS WILL OCCUR 300 FEET UPSTREAM OR 100 FEET DOWNSTREAM OF AN EXISTING REDD OR SPAWNING FISH; AND
 - 4. AFTER PROJECT COMPLETION, TEMPORARY STREAM CROSSINGS WILL BE OBLITERATED AND BANKS RESTORED.

7. STAGING, STORAGE, AND STOCKPILE AREAS

- A. STAGING AREAS (USED FOR CONSTRUCTION EQUIPMENT STORAGE, VEHICLE STORAGE, FUELING, SERVICING, AND HAZARDOUS MATERIAL STORAGE) WILL BE 150 FEET OR MORE FROM ANY NATURAL WATER BODY OR WETLAND. STAGING AREAS CLOSER THAN 150 FEET WILL BE APPROVED BY THE EC LEAD.
- B. NATURAL MATERIALS USED FOR IMPLEMENTATION OF AQUATIC RESTORATION, SUCH AS LARGE WOOD, GRAVEL, AND BOULDERS, MAY BE STAGED WITHIN 150 FEET IF CLEARLY INDICATED IN THE PLANS THAT AREA IS FOR NATURAL MATERIALS ONLY.
- C. ANY LARGE WOOD, TOPSOIL, AND NATIVE CHANNEL MATERIAL DISPLACED BY CONSTRUCTION WILL BE STOCKPILED FOR USE DURING SITE RESTORATION AT A SPECIFICALLY IDENTIFIED AND FLAGGED AREA.
- D. ANY MATERIAL NOT USED IN RESTORATION, AND NOT NATIVE TO THE FLOODPLAIN, WILL BE DISPOSED OF OUTSIDE THE 100-YEAR FLOODPLAIN.

8. EQUIPMENT

- A. MECHANIZED EQUIPMENT AND VEHICLES WILL BE SELECTED, OPERATED, AND MAINTAINED IN A MANNER THAT MINIMIZES ADVERSE EFFECTS ON THE ENVIRONMENT (E.G., MINIMALLY-SIZED, LOW PRESSURE TIRES; MINIMAL HARD-TURN PATHS FOR TRACKED VEHICLES; TEMPORARY MATS OR PLATES WITHIN WET AREAS OR ON SENSITIVE SOILS).
- B. EQUIPMENT WILL BE STORED, FUELED, AND MAINTAINED IN AN CLEARLY IDENTIFIED STAGING AREA THAT MEETS STAGING AREA CONSERVATION MEASURES.
- C. EQUIPMENT WILL BE REFUELED IN A VEHICLE STAGING AREA OR IN AN ISOLATED HARD ZONE, SUCH AS A PAVED PARKING LOT OR ADJACENT, ESTABLISHED ROAD (THIS MEASURE APPLIES ONLY TO GAS-POWERED EQUIPMENT WITH TANKS LARGER THAN 5 GALLONS).
- D. BIODEGRADABLE LUBRICANTS AND FLUIDS WILL BE USED ON EQUIPMENT OPERATING IN AND ADJACENT TO THE STREAM CHANNEL AND LIVE WATER.
- E. EQUIPMENT WILL BE INSPECTED DAILY FOR FLUID LEAKS BEFORE LEAVING THE VEHICLE STAGING AREA FOR OPERATION WITHIN 150 FEET OF ANY NATURAL WATER BODY OR WETLAND.
- F. EQUIPMENT WILL BE THOROUGHLY CLEANED BEFORE OPERATION BELOW ORDINARY HIGH WATER, AND AS OFTEN AS NECESSARY DURING OPERATION, TO REMAIN GREASE FREE.

9. EROSION CONTROL

- A. TEMPORARY EROSION CONTROL MEASURES INCLUDE:
 - 1. TEMPORARY EROSION CONTROLS WILL BE IN PLACE BEFORE ANY SIGNIFICANT ALTERATION OF THE ACTION SITE AND APPROPRIATELY INSTALLED DOWNSLOPE OF PROJECT ACTIVITY WITHIN THE RIPARIAN BUFFER AREA UNTIL SITE REHABILITATION IS COMPLETE;
 - 2. IF THERE IS A POTENTIAL FOR ERODED SEDIMENT TO ENTER THE STREAM, SEDIMENT BARRIERS WILL BE INSTALLED AND MAINTAINED FOR THE DURATION OF PROJECT IMPLEMENTATION;
 - 3. TEMPORARY EROSION CONTROL MEASURES MAY INCLUDE SEDGE MATS, FIBER WATTLES, SILT FENCES, JUTE MATTING, WOOD FIBER MULCH AND SOIL BINDER, OR GEOTEXTILES AND GEOSYNTHETIC FABRIC;
 - 4. SOIL STABILIZATION UTILIZING WOOD FIBER MULCH AND TACKIFIER (HYDRO-APPLIED) MAY BE USED TO REDUCE EROSION OF BARE SOIL IF THE MATERIALS ARE NOXIOUS WEED FREE AND NONTOXIC TO AQUATIC AND TERRESTRIAL ANIMALS, SOIL MICROORGANISMS, AND VEGETATION;
 - 5. SEDIMENT WILL BE REMOVED FROM EROSION CONTROLS ONCE IT HAS REACHED 1/3 OF THE EXPOSED HEIGHT OF THE CONTROL; AND
 - 6. ONCE THE SITE IS STABILIZED AFTER CONSTRUCTION, TEMPORARY EROSION CONTROL MEASURES WILL BE REMOVED.
- B. EMERGENCY EROSION CONTROLS. THE FOLLOWING MATERIALS FOR EMERGENCY EROSION CONTROL WILL BE AVAILABLE AT THE WORK SITE:
 - 1. A SUPPLY OF SEDIMENT CONTROL MATERIALS; AND
 - 2. AN OIL-ABSORBING FLOATING BOOM WHENEVER SURFACE WATER IS PRESENT.

10. DUST ABATEMENT

- A. THE PROJECT SPONSOR WILL DETERMINE THE APPROPRIATE DUST CONTROL MEASURES BY CONSIDERING SOIL TYPE, EQUIPMENT USAGE, PREVAILING WIND DIRECTION, AND THE EFFECTS CAUSED BY OTHER EROSION AND SEDIMENT CONTROL MEASURES.
- B. WORK WILL BE SEQUENCED AND SCHEDULED TO REDUCE EXPOSED BARE SOIL SUBJECT TO WIND EROSION.
- C. DUST-ABATEMENT ADDITIVES AND STABILIZATION CHEMICALS (TYPICALLY MAGNESIUM CHLORIDE, CALCIUM CHLORIDE SALTS, OR LIGNINSULFONATE) WILL NOT BE APPLIED WITHIN 25 FEET OF WATER OR A STREAM CHANNEL AND WILL BE APPLIED SO AS TO MINIMIZE THE LIKELIHOOD THAT THEY WILL ENTER STREAMS. APPLICATIONS OF LIGNINSULFONATE WILL BE LIMITED TO A MAXIMUM RATE OF 0.5 GALLONS PER SQUARE YARD OF ROAD SURFACE, ASSUMING MIXED 50:50 WITH WATER.
- D. APPLICATION OF DUST ABATEMENT CHEMICALS WILL BE AVOIDED DURING OR JUST BEFORE WET WEATHER, AND AT STREAM CROSSINGS OR OTHER AREAS THAT COULD RESULT IN UNFILTERED DELIVERY OF THE DUST ABATEMENT MATERIALS TO A WATERBODY (TYPICALLY THESE WOULD BE AREAS WITHIN 25 FEET OF A WATERBODY OR STREAM CHANNEL; DISTANCES MAY BE GREATER WHERE VEGETATION IS SPARSE OR SLOPES ARE STEEP).
- E. SPILL CONTAINMENT EQUIPMENT WILL BE AVAILABLE DURING APPLICATION OF DUST ABATEMENT CHEMICALS.
- F. PETROLEUM-BASED PRODUCTS WILL NOT BE USED FOR DUST ABATEMENT.

11. SPILL PREVENTION, CONTROL, AND COUNTER MEASURES

- A. A DESCRIPTION OF HAZARDOUS MATERIALS THAT WILL BE USED, INCLUDING INVENTORY, STORAGE, AND HANDLING PROCEDURES WILL BE AVAILABLE ON-SITE.
- B. WRITTEN PROCEDURES FOR NOTIFYING ENVIRONMENTAL RESPONSE AGENCIES WILL BE POSTED AT THE WORK SITE.
- C. SPILL CONTAINMENT KITS (INCLUDING INSTRUCTIONS FOR CLEANUP AND DISPOSAL) ADEQUATE FOR THE TYPES AND QUANTITY OF HAZARDOUS MATERIALS USED AT THE SITE WILL BE AVAILABLE AT THE WORK SITE.
- D. WORKERS WILL BE TRAINED IN SPILL CONTAINMENT PROCEDURES AND WILL BE INFORMED OF THE LOCATION OF SPILL CONTAINMENT KITS.
- E. ANY WASTE LIQUIDS GENERATED AT THE STAGING AREAS WILL BE TEMPORARILY STORED UNDER AN IMPERVIOUS COVER, SUCH AS A TARPAULIN, UNTIL THEY CAN BE PROPERLY TRANSPORTED TO AND DISPOSED OF AT A FACILITY THAT IS APPROVED FOR RECEIPT OF HAZARDOUS MATERIALS.
- F. PUMPS USED ADJACENT TO WATER SHALL USE SPILL CONTAINMENT SYSTEMS.

12. INVASIVE SPECIES CONTROL

- A. PRIOR TO ENTERING THE SITE, ALL VEHICLES AND EQUIPMENT WILL BE POWER WASHED, ALLOWED TO FULLY DRY, AND INSPECTED TO MAKE SURE NO PLANTS, SOIL, OR OTHER ORGANIC MATERIAL ADHERES TO THE SURFACE.
- B. WATERCRAFT, WADERS, BOOTS, AND ANY OTHER GEAR TO BE USED IN OR NEAR WATER WILL BE INSPECTED FOR AQUATIC INVASIVE SPECIES.
- C. WADING BOOTS WITH FELT SOLES ARE NOT TO BE USED DUE TO THEIR PROPENSITY FOR AIDING IN THE TRANSFER OF INVASIVE SPECIES UNLESS DECONTAMINATION PROCEDURES HAVE BEEN APPROVED BY THE EC LEAD.



501 Portway Avenue, Suite 101
Hood River, OR 97031
541.386.9003
www.interfluve.com

ALWAYS THINK SAFETY

U.S. DEPARTMENT OF THE INTERIOR
BUREAU OF RECLAMATION
COLUMBIA PACIFIC NORTHWEST REGION
FCRPS HABITAT IMPROVEMENT PROGRAM

LOWER CHIWAWA RIVER PROJECT
PROJECT AREA G - PHASE 2
DRAFT FINAL DESIGN

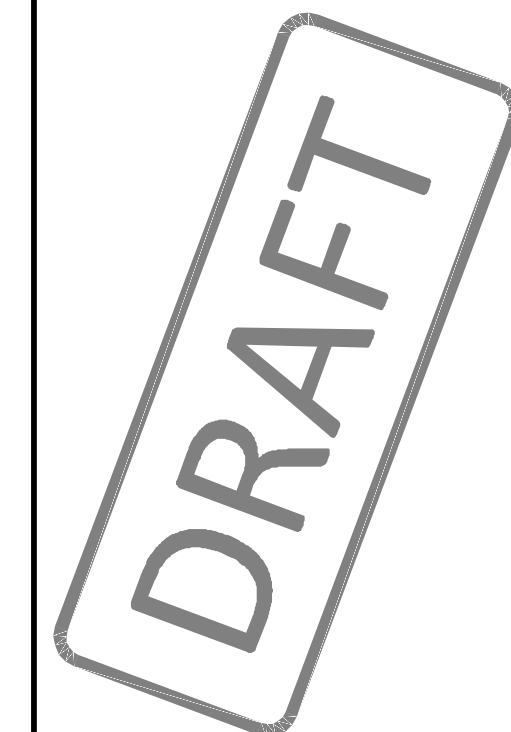

CM
DRAWN

LS_PB
ACCEPTED

BOISE, ID APRIL 27, 2026

GENERAL
CONSERVATION
MEASURES (1 OF 3)

SHEET 3

SHEET 3 OF 15

LAST SAVED DATE
2026-04-29
LAST SAVED BY
GREGORWELL

CAD SYSTEM
AutoCAD 2015 LT (LMS TECH)
JFL LOWERCHIWAWA_AREA_G_D.DWG

WORK AREA ISOLATION AND FISH SALVAGE

1. WORK AREA ISOLATION

- A. ANY WORK AREA WITHIN THE WETTED CHANNEL WILL BE ISOLATED FROM THE ACTIVE STREAM WHENEVER ESA-LISTED FISH ARE REASONABLY CERTAIN TO BE PRESENT, OR IF THE WORK AREA IS LESS THAN 300-FEET UPSTREAM FROM KNOWN SPAWNING HABITATS.
- B. WORK AREA ISOLATION AND FISH SALVAGE ACTIVITIES WILL COMPLY WITH THE IN-WATER WORK WINDOW.
- C. DESIGN PLANS WILL INCLUDE ALL ISOLATION ELEMENTS AND AREAS (COFFER DAMS, PUMPS, DISCHARGE AREAS, FISH SCREENS, FISH RELEASE AREAS, ETC.).
- D. WORK AREA ISOLATION AND FISH CAPTURE ACTIVITIES WILL OCCUR DURING PERIODS OF THE COOLEST AIR AND WATER TEMPERATURES POSSIBLE, NORMALLY EARLY IN THE MORNING VERSUS LATE IN THE DAY, AND DURING CONDITIONS APPROPRIATE TO MINIMIZE STRESS AND DEATH OF SPECIES PRESENT.

2. FISH SALVAGE

- A. MONITORING AND RECORDING WILL TAKE PLACE FOR DURATION OF SALVAGE. THE SALVAGE REPORT WILL BE COMMUNICATED TO AGENCIES VIA THE PROJECT COMPLETION FORM (PCF).
- B. SALVAGE ACTIVITIES SHOULD TAKE PLACE DURING CONDITIONS TO MINIMIZE STRESS TO FISH SPECIES, TYPICALLY PERIODS OF THE COOLEST AIR AND WATER TEMPERATURES WHICH OCCUR IN THE MORNING VERSUS LATE IN THE DAY.
- C. SALVAGE OPERATIONS WILL FOLLOW THE ORDERING, METHODS, AND CONSERVATION MEASURES SPECIFIED BELOW:
 - 1. SLOWLY REDUCE WATER FROM THE WORK AREA TO ALLOW SOME FISH TO LEAVE VOLITIONALLY.
 - 2. BLOCK NETS WILL BE INSTALLED AT UPSTREAM AND DOWNSTREAM LOCATIONS AND MAINTAINED IN A SECURED POSITION TO EXCLUDE FISH FROM ENTERING THE PROJECT AREA.
 - 3. BLOCK NETS WILL BE SECURED TO THE STREAM CHANNEL BED AND BANKS UNTIL FISH CAPTURE AND TRANSPORT ACTIVITIES ARE COMPLETE. BLOCK NETS MAY BE LEFT IN PLACE FOR THE DURATION OF THE PROJECT TO EXCLUDE FISH AS LONG AS PASSAGE REQUIREMENTS ARE MET.
 - 4. NETS WILL BE MONITORED HOURLY DURING IN-STREAM DISTURBANCE.
 - 5. IF BLOCK NETS REMAIN IN PLACE MORE THAN ONE DAY, THE NETS WILL BE MONITORED AT LEAST DAILY TO ENSURE THEY ARE SECURED AND FREE OF ORGANIC ACCUMULATION. IF BULL TROUT ARE PRESENT, NETS ARE TO BE CHECKED EVERY 4 HOURS FOR FISH IMPINGEMENT.
 - 6. CAPTURE FISH THROUGH SEINING AND RELOCATE TO STREAMS.
 - 7. WHILE DEWATERING, ANY REMAINING FISH WILL BE COLLECTED BY HAND OR DIP NETS.
 - 8. SEINES WITH A MESH SIZE TO ENSURE CAPTURE OF THE RESIDING ESA-LISTED FISH WILL BE USED.
 - 9. MINNOW TRAPS WILL BE LEFT IN PLACE OVERNIGHT AND USED IN CONJUNCTION WITH SEINING.
 - 10. ELECTROFISH TO CAPTURE AND RELOCATED FISH NOT CAUGHT DURING SEINING PER ELECTROFISH CONSERVATION MEASURES.
 - 11. CONTINUE TO SLOWLY DEWATER STREAM REACH.
 - 12. COLLECT ANY REMAINING FISH IN COLD-WATER BUCKETS AND RELOCATED TO THE STREAM.
 - 13. LIMIT THE TIME FISH ARE IN A TRANSPORT BUCKET.
 - 14. MINIMIZE PREDATION BY TRANSPORTING COMPARABLE SIZES IN BUCKETS.
 - 15. BUCKET WATER TO BE CHANGED EVERY 15 MINUTES OR AERATED.
 - 16. BUCKETS WILL BE KEPT IN SHADED AREAS OR COVERED.
 - 17. DEAD FISH WILL NOT BE STORED IN TRANSPORT BUCKETS, BUT WILL BE LEFT ON THE STREAM BANK TO AVOID MORTALITY COUNTING ERRORS.
- D. SALVAGE GUIDELINES FOR BULL TROUT, LAMPREY, MUSSELS, AND NATIVE FISH
 - 1. CONDUCT SITE SURVEY TO ESTIMATE SALVAGE NUMBERS.
 - 2. PRE-SELECT SITE(S) FOR RELEASE AND/OR MUSSEL BED RELOCATION.
 - 3. SALVAGE OF BULL TROUT WILL NOT TAKE PLACE WHEN WATER TEMPERATURES EXCEED 15 DEGREES CELSIUS.
 - 4. IF DRAWDOWN LESS THAN 48 HOURS, SALVAGE OF LAMPREY AND MUSSELS MAY NOT BE NECESSARY IF TEMPERATURES SUPPORT SURVIVAL IN SEDIMENTS.
 - 5. SALVAGE MUSSELS BY HAND, LOCATING BY SNORKELING OR WADING.
 - 6. SALVAGE LAMPREY BY ELECTROFISHING (SEE ELECTROFISHING FOR LARVAL LAMPREY SETTINGS AND LARVAL LAMPREY DRY SHOCKING SETTINGS).
 - 7. SALVAGE BONY FISH AFTER LAMPREY WITH NETS OR ELECTROFISHING (SEE ELECTROFISHING FOR APPROPRIATE SETTINGS).
 - 8. REGULARLY INSPECT DEWATERED SITE SINCE LAMPREY LIKELY TO EMERGE AFTER DEWATERING AND MUSSELS MAY BECOME VISIBLE.
 - 9. MUSSELS MAY BE TRANSFERRED IN COOLERS.
 - 10. MUSSELS WILL BE PLACED INDIVIDUALLY TO ENSURE ABILITY TO BURROW INTO NEW HABITAT.

3. ELECTROFISHING

- A. INITIAL SITE SURVEY AND INITIAL SETTINGS
 - 1. IDENTIFY SPAWNING ADULTS AND ACTIVE REDDS TO AVOID.
 - 2. RECORD WATER TEMPERATURE. ELECTROFISHING WILL NOT OCCUR WHEN WATER TEMPERATURES ARE ABOVE 18 DEGREES CELSIUS.
 - 3. IF POSSIBLE, A BLOCK NET WILL BE PLACED DOWNSTREAM AND CHECKED REGULARLY TO CAPTURE STUNNED FISH THAT DRIFT DOWNSTREAM.
 - 4. INITIAL SETTINGS WILL BE 100 VOLTS, PULSE WIDTH OF 500 MICRO SECONDS, AND PULSE RATE OF 30 HERTZ.
 - 5. RECORDS FOR CONDUCTIVITY, WATER TEMPERATURE, AIR TEMPERATURE, ELECTROFISHING SETTINGS, ELECTROFISHER MODEL, ELECTROFISHER CALIBRATION, FISH CONDITIONS, FISH MORTALITIES, AND TOTAL CAPTURE RATES WILL BE INCLUDED IN THE SALVAGE LOG BOOK.
- B. ELECTROFISHING TECHNIQUE
 - 1. SAMPLING WILL BEGIN USING STRAIGHT DC. POWER WILL REMAIN ON UNTIL THE FISH IS NETTED WHEN USING STRAIGHT DC GRADUALLY INCREASE VOLTAGE WHILE REMAINING BELOW MAXIMUM LEVELS.
 - 2. MAXIMUM VOLTAGE WILL BE 1100 VOLTS WHEN CONDUCTIVITY IS <100 MILLISECONDS, 800 VOLTS WHEN CONDUCTIVITY IS BETWEEN 100 AND 300 MILLISECONDS, AND 400 VOLTS WHEN CONDUCTIVITY IS >300 MILLISECONDS.
 - 3. IF FISH CAPTURE IS NOT SUCCESSFUL USING STRAIGHT DC, THE ELECTROFISHER WILL BE SET TO INITIAL VOLTAGE FOR PDC. VOLTAGE, PULSE WIDTH, AND PULSE FREQUENCY WILL BE GRADUALLY INCREASED WITHIN MAXIMUM VALUES UNTIL CAPTURE IS SUCCESSFUL.
 - 4. MAXIMUM PULSE WIDTH IS 5 MILLISECONDS. MAXIMUM PULSE RATE IS 70 HERTZ
 - 5. ELECTROFISHING WILL NOT OCCUR IN ONE AREA FOR AN EXTENDED PERIOD.
 - 6. THE ANODE WILL NOT INTENTIONALLY COME INTO CONTACT WITH FISH. THE ZONE FOR POTENTIAL INJURY OF 0.5 M FROM THE ANODE WILL BE AVOIDED.
 - 7. SETTINGS WILL BE LOWERED IN SHALLOWER WATER SINCE VOLTAGE GRADIENTS LIKELY TO INCREASE.
 - 8. ELECTROFISHING WILL NOT OCCUR IN TURBID WATER WHERE VISIBILITY IS POOR (I.E. UNABLE TO SEE THE BED OF THE STREAM).
 - 9. OPERATIONS WILL IMMEDIATELY STOP IF MORTALITY OR OBVIOUS FISH INJURY IS OBSERVED. ELECTROFISHING SETTINGS WILL BE REEVALUATED.
- C. SAMPLE PROCESSING
 - 1. FISH SHALL BE SORTED BY SIZE TO AVOID PREDATION DURING CONTAINMENT.
 - 2. SAMPLERS WILL REGULARLY CHECK CONDITIONS OF FISH HOLDING CONTAINERS, AIR PUMPS, WATER TRANSFERS, ETC.
 - 3. FISH WILL BE OBSERVED FOR GENERAL CONDITIONS AND INJURIES
 - 4. EACH FISH WILL BE COMPLETELY REVIVED BEFORE RELEASE. ESA-LISTED SPECIES WILL BE PRIORITIZED FOR SUCCESSFUL RELEASE.
- D. BULL TROUT ELECTROFISHING
 - 1. ELECTROFISHING FOR BULL TROUT WILL ONLY OCCUR FROM MAY 1 TO JULY 31. NO ELECTROFISHING WILL OCCUR IN ANY BULL TROUT OCCUPIED HABITAT AFTER AUGUST 15. IN FMO HABITATS ELECTROFISHING MAY OCCUR ANY TIME.
 - 2. ELECTROFISHING OF BULL TROUT WILL NOT OCCUR WHEN WATER TEMPERATURES EXCEED 15 DEGREES CELSIUS.

E. LARVAL LAMPREY ELECTROFISHING

- 1. PERMISSION FROM EC LEAD WILL BE OBTAINED IF LARVAL LAMPREY ELECTROFISHER IS NOT ONE OF FOLLOWING PRE-APPROVED MODELS: ABP-2 "WISCONSIN", SMITH-ROOT LR-24, OR SMITH-ROOT APEX BACKPACK.
- 2. LARVAL LAMPREY SAMPLING WILL INCORPORATE 2-STAGE METHOD: "TICKLE" AND "STUN".
- 3. FIRST STAGE: USE 125 VOLT DC WITH A 25 PERCENT DUTY CYCLE APPLIED AT A SLOW RATE OF 3 PULSES PER SECOND. IF TEMPERATURES ARE BELOW 10 DEGREES CELSIUS, VOLTAGE MAY BE INCREASED GRADUALLY (NOT TO EXCEED 200 VOLTS). BURSTED PULSES (THREE SLOW AND ONE SKIPPED) RECOMMENDED TO INCREASE EMERGENCE.
- 4. SECOND STAGE (OPTIONAL FOR EXPERIENCED NETTERS): IMMEDIATELY AFTER LAMPREY EMERGE, USE A FAST PULSE SETTING OF 30 PULSES PER SECOND.
- 5. USE DIP NETS FOR VISIBLE LAMPREY. SIENES AND FINE MESH NET SWEEPS MAY BE USED IN POOR VISIBILITY.
- 6. SAMPLING WILL OCCUR SLOWLY (>60 SECONDS PER METER) STARTING AT UPSTREAM AND WORKING DOWNSTREAM.
- 7. MULTIPLE SWEEPS TO OCCUR WITH 15 MINUTES BETWEEN SWEEPS.
- 8. POST-DRAWDOWN "DRY-SHOCKING" WILL BE APPLIED IF LARVAL LAMPREY CONTINUE TO EMERGE. ANODES TO BE PLACED ONE METER APART TO SAMPLE ONE SQUARE METER AT A TIME FOR AT LEAST 60 SECONDS. FOR TEMPERATURES LESS THAN 10 DEGREES CELSIUS, MAXIMUM VOLTAGE MAY BE GRADUALLY INCREASED TO 400 VOLTS (DRY-SHOCKING ONLY).

4. DEWATERING

- C. DEWATERING WILL OCCUR AT A RATE SLOW ENOUGH TO ALLOW SPECIES TO NATURALLY MIGRATE OUT OF THE WORK AREA.
- D. WHERE A GRAVITY FEED DIVERSION IS NOT POSSIBLE, A PUMP MAY BE USED. PUMPS WILL BE INSTALLED TO AVOID REPETIVE DEWATERING AND REWATERING.
- E. WHEN FISH ARE PRESENT, PUMPS WILL BE SCREENED IN ACCORDANCE WITH NMFS FISH SCREEN CRITERIA. NMFS ENGINEERING REVIEW AND APPROVAL WILL BE OBTAINED FOR PUMPS EXCEEDING 3 CUBIC FEET PER SECOND.
- F. DISSIPATION OF FLOW ENERGY AT THE BYPASS OUTFLOW WILL BE PROVIDED TO PREVENT DAMAGE TO THE STREAM CHANNEL AND RIPARIAN VEGETATION.
- G. SEEPAGE WATER WILL BE PUMPED TO A TEMPORARY STORAGE AND TREATMENT SITE OF INTO UPLAND AREAS TO ALLOW WATER TO PERCOLATE THROUGH SOIL AND VEGETATION PRIOR TO REENTERING THE STREAM CHANNEL.

CAD SYSTEM AutoCAD 2015 (LMS TECH) JFL LOWERCHIVAWA_AREA_G_D.DWG
LAST SAVED DATE 2026-04-29 LMS SAVED BY GREGORWELL



ALWAYS THINK SAFETY
U.S. DEPARTMENT OF THE INTERIOR
BUREAU OF RECLAMATION
COLUMBIA PACIFIC NORTHWEST REGION
FCRPS HABITAT IMPROVEMENT PROGRAM
LOWER CHIVAWA RIVER PROJECT
PROJECT AREA G - PHASE 2
DRAFT FINAL DESIGN

DRAFT

CM DRAWN
LS, PB ACCEPTED
BOISE, ID APRIL 27, 2026

GENERAL CONSERVATION MEASURES (2 OF 3)
SHEET 4

CONSTRUCTION AND POST CONSTRUCTION CONSERVATION MEASURES.

1. FISH PASSAGE

- A. FISH PASSAGE WILL BE PROVIDED FOR ADULT AND JUVENILE FISH LIKELY TO BE PRESENT DURING CONSTRUCTION UNLESS PASSAGE DID NOT EXIST BEFORE CONSTRUCTION, THE STREAM IS NATURALLY IMPASSABLE, OR PASSAGE WILL NEGATIVELY IMPACT ESA-LISTED SPECIES OR THEIR HABITAT.
- B. FISH PASSAGE ALTERNATIVES WILL BE APPROVED UNDER ADVISEMENT BY THE NMFS HABITAT BIOLOGIST.

2. CONSTRUCTION AND DISCHARGE WATER

- A. SURFACE WATER MAY BE DIVERTED TO MEET CONSTRUCTION NEEDS ONLY IF DEVELOPED SOURCES ARE UNAVAILABLE OR INADEQUATE.
- B. DIVERSIONS WILL NOT EXCEED 10% OF THE AVAILABLE FLOW.
- C. CONSTRUCTION DISCHARGE WATER WILL BE COLLECTED AND TREATED TO REMOVE DEBRIS, NUTRIENTS, SEDIMENT, PETROLEUM HYDROCARBONS, METALS, AND OTHER POLLUTANTS.

3. TIME AND EXTENT OF DISTURBANCE

- A. EARTHWORK REQUIRING IN-STREAM MECHANIZED EQUIPMENT (INCLUDING DRILLING, EXCAVATION, DREDGING, FILLING, AND COMPACTING) WILL BE COMPLETED AS QUICKLY AS POSSIBLE.
- B. MECHANIZED EQUIPMENT WILL WORK FROM TOP OF BANK UNLESS WORK FROM ANOTHER LOCATION WILL RESULT IN LESS HABITAT DISTURBANCE (TURBIDITY, VEGETATION DISTURBANCE, ETC.).

4. CESSATION OF WORK

- A. PROJECT OPERATIONS WILL CEASE WHEN HIGH FLOW CONDITIONS MAY RESULT IN INUNDATION OF THE PROJECT AREA (FLOOD EFFORTS TO DECREASE DAMAGES TO NATURAL RESOURCES PERMITTED).
- B. WATER QUALITY LEVELS EXCEEDED. SEE CWA SECTION 401 WATER QUALITY CERTIFICATION AND TURBIDITY MEASURES.

5. SITE RESTORATION

- A. DISTURBED AREAS, STREAM BANKS, SOILS, AND VEGETATION WILL BE CLEANED UP AND RESTORED TO IMPROVED OR PRE-PROJECT CONDITIONS.
- B. PROJECT-RELATED WASTE WILL BE REMOVED.
- C. TEMPORARY ACCESS ROADS AND STAGING WILL BE DECOMPACTED AND RESTORED. SOILS WILL BE LOOSENED IF NEEDED FOR REVEGETATION OR WATER INFILTRATION.
- D. THE PROJECT SPONSOR WILL RETAIN THE RIGHT OF REASONABLE ACCESS TO THE SITE TO MONITOR AND MAINTAIN THE SITE OVER THE LIFE OF THE PROJECT.

6. REVEGETATION

- A. PLANTING AND SEEDING WILL OCCUR PRIOR TO OR AT THE BEGINNING OF THE FIRST GROWING SEASON AFTER CONSTRUCTION.
- B. A MIX OF NATIVE SPECIES (INVASIVE SPECIES NOT ALLOWED) APPROPRIATE TO THE SITE WILL BE USED TO REESTABLISH VEGETATION, PROVIDE SHADE, AND REDUCE EROSION. REESTABLISHED VEGETATION SHOULD BE AT LEAST 70% OF PRE-PROJECT CONDITIONS WITHIN THREE YEARS.
- C. VEGETATION SUCH AS WILLOWS, SEDGES, OR RUSH MATS WILL BE SALVAGED FROM DISTURBED OR ABANDONED AREAS TO BE REPLANTED.
- D. SHORT-TERM STABILIZATION MEASURE MAY INCLUDE THE USE OF NON-NATIVE STERILE SEED MIX (WHEN NATIVE NOT AVAILABLE), WEED-FREE CERTIFIED STRAW, OR OTHER SIMILAR TECHNIQUES.
- E. SURFACE FERTILIZER WILL NOT BE APPLIED WITHIN 50 FEET OF ANY STREAM, WATE BODY, OR WETLAND.
- F. FENCING WILL BE INSTALLED AS NECESSARY TO PREVENT ACCESS TO REVEGETATED SITES BY LIVESTOCK OR UNAUTHORIZED PERSONS.
- G. INVASIVE PLANTS WILL BE REMOVED OR CONTROLLED UNTIL NATIVE PLANT SPECIES ARE WELL ESTABLISHED (TYPICALLY THREE YEARS POST-CONSTRUCTION).

7. SITE ACCESS AND IMPLEMENTATION MONITORING

- A. THE PROJECT SPONSOR WILL PROVIDE CONSTRUCTION MONITORING DURING IMPLEMENTATION TO ENSURE ALL CONSERVATION MEASURES ARE ADEQUATELY FOLLOWED, EFFECTS TO LISTED SPECIES ARE NOT GREATER THAN PREDICTED, AND INCIDENTAL TAKE LIMITATIONS ARE NOT EXCEEDED.
- B. THE PROJECT SPONSOR OR DESIGNATED REPRESENTATIVE WILL SUBMIT THE PROJECT COMPLETION FORM (PCF) WITHIN 30 DAYS OF PROJECT COMPLETION.

8. CWA SECTION 401 WATER QUALITY CERTIFICATION

- A. THE PROJECT SPONSOR OR DESIGNATED REPRESENTATIVE WILL COMPLETE AND RECORD WATER QUALITY OBSERVATIONS (SEE TURBIDITY MONITORING) TO ENSURE IN-WATER WORK IS NOT DEGRADING WATER QUALITY.
- B. DURING CONSTRUCTION, WATER QUALITY PROVISIONS PROVIDED BY THE OREGON DEPARTMENT OF ENVIRONMENTAL QUALITY, WASHINGTON DEPARTMENT OF ECOLOGY.

STAGED REWATERING PLAN

- A. WHEN REINTRODUCING WATER TO DEWATERED AREAS AND NEWLY CONSTRUCTED CHANNELS, A STAGED REWATERING PLAN WILL BE APPLIED.
- B. THE FOLLOWING WILL BE APPLIED TO ALL REWATERING EFFORTS. COMPLEX REWATERING EFFORTS MAY REQUIRE ADDITIONAL NOTES OR A DEDICATED SHEET IN THE CONSTRUCTION DETAILS.
 - 1. TURBIDITY MONITORING PROTOCOL WILL BE APPLIED TO REWATERING EFFORTS.
 - 2. PRE-WASH THE AREA BEFORE REWATERING. TURBID WASH WATER WILL BE DETAINED AND PUMPED TO THE FLOODPLAIN OR SEDIMENT CAPTURE AREAS RATHER THAN DISCHARGING TO FISH-BEARING STREAMS.
 - 3. INSTALL SEINE NETS AT UPSTREAM END TO PREVENT FISH FROM MOVING DOWNSTREAM UNTIL 2/3 OF TOTAL FLOW IS RESTORED TO THE CHANNEL.
 - 4. STARTING IN EARLY MORNING INTRODUCE 1/3 OF NEW CHANNEL FLOW OVER PERIOD OF 1-2 HOURS.
 - 5. INTRODUCE SECOND THIRD OF FLOW OVER NEXT 1 TO 2 HOURS AND BEGIN FISH SALVAGE OF BYPASS CHANNEL IF FISH ARE PRESENT.
 - 6. REMOVE UPSTREAM SEINE NETS ONCE 2/3 FLOW IN REWATERED CHANNEL AND DOWNSTREAM TURBIDITY IS WITHIN ACCEPTABLE RANGE (LESS THAN 40 NTU OR LESS THAN 10% BACKGROUND).
 - 7. INTRODUCE FINAL THIRD OF FLOW ONCE FISH SALVAGE EFFORTS ARE COMPLETE AND DOWNSTREAM TURBIDITY VERIFIED TO BE WITHIN ACCEPTABLE RANGE.
 - 8. INSTALL PLUG TO BLOCK FLOW INTO OLD CHANNEL OR BYPASS. REMOVE ANY REMAINING SEINE NETS.
 - 9. IN LAMPREY SYSTEMS, LAMPREY SALVAGE AND DRY SHOCKING MAY BE NECESSARY.

TURBIDITY MONITORING

- A. RECORD THE READING, LOCATION, AND TIME FOR THE BACKGROUND READING APPROXIMATELY 100 FEET UPSTREAM OF THE PROJECT AREA USING A RECENTLY CALIBRATED TURBIDIMETER OR VIA VISUAL OBSERVATION.
- B. RECORD THE TURBIDITY READING, LOCATION, AND TIME AT THE MEASUREMENT COMPLIANCE LOCATION POINT.
 - 1. 50 FEET DOWNSTREAM FOR STREAMS LESS THAN 30 FEET WIDE.
 - 2. 100 FEET DOWNSTREAM FOR STREAMS BETWEEN 30 AND 100 FEET WIDE.
 - 3. 200 FEET DOWNSTREAM FOR STREAMS GREATER THAN 100 FEET WIDE.
 - 4. 300 FEET FROM THE DISCHARGE POINT OR NONPOINT SOURCE FOR LOCATIONS SUBJECT TO TIDAL OR COASTAL SCOUR.
- C. TURBIDITY SHALL BE MEASURED (BACKGROUND LOCATION AND COMPLIANCE POINTS) EVERY 4 HOURS WHILE WORK IS BEING IMPLEMENTED.
- D. IF THERE IS A VISIBLE DIFFERENCE BETWEEN A COMPLIANCE POINT AND THE BACKGROUND, THE EXCEEDANCE WILL BE NOTED IN THE PROJECT COMPLETION FORM (PCF). ADJUSTMENTS OR CORRECTIVE MEASURES WILL BE TAKEN IN ORDER TO REDUCE TURBIDITY.
- E. IF EXCEEDANCES OCCUR FOR MORE THAN TWO CONSECUTIVE MONITORING INTERVALS (AFTER 8 HOURS), THE ACTIVITY WILL STOP UNTIL THE TURBIDITY LEVEL RETURNS TO BACKGROUND. THE BPA EC LEAD WILL BE NOTIFIED OF ALL EXCEEDANCES AND CORRECTIVE ACTIONS AT PROJECT COMPLETION.
- F. IF TURBIDITY CONTROLS (COFFER DAMS, WADDLES, FENCING, ETC.) ARE DETERMINED INEFFECTIVE, CREWS WILL BE MOBILIZED TO MODIFY AS NECESSARY. OCCURRENCES WILL BE DOCUMENTED IN THE PROJECT COMPLETION FORM (PCF).
- G. FINAL TURBIDITY READINGS, EXCEEDANCES, AND CONTROL FAILURES WILL BE SUBMITTED TO THE BPA EC LEAD USING THE PROJECT COMPLETION FORM (PCF).

LAST SAVED DATE
2026-04-29
LAST SAVED BY
LUCASWELL

CAD SYSTEM
AutoCAD 2015 (LMS TECH)
PLT LOWERCHIVAWA_AREA_G.DWG

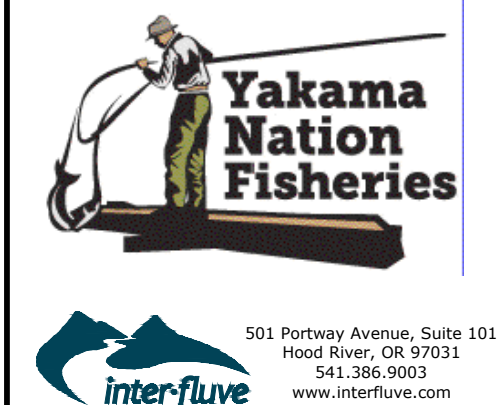

ALWAYS THINK SAFETY



U.S. DEPARTMENT OF THE INTERIOR
BUREAU OF RECLAMATION

COLUMBIA PACIFIC NORTHWEST REGION
FCRPS HABITAT IMPROVEMENT PROGRAM

LOWER CHIVAWA RIVER PROJECT
PROJECT AREA G - PHASE 2

DRAFT FINAL DESIGN

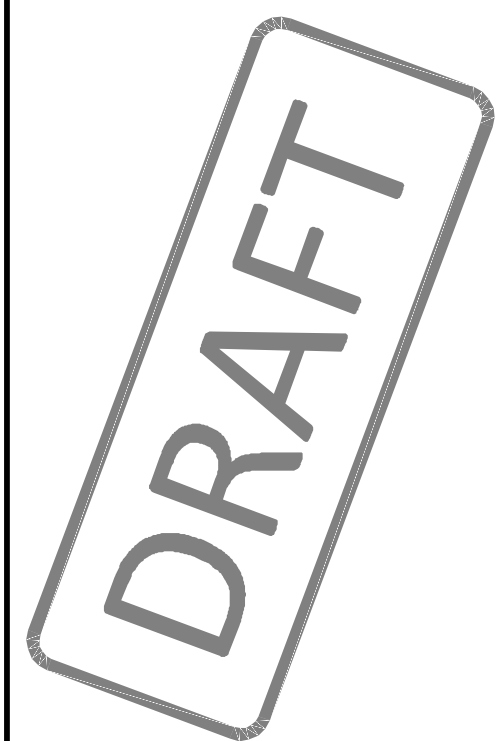

CM
DRAWN

LS, PB
ACCEPTED

BOISE, ID

APRIL 27, 2026

GENERAL
CONSERVATION
MEASURES (3 OF 3)

SHEET 4

SHEET 5 OF 15

SHEET PILE NOTES:

1. SHEET PILE MATERIAL SHALL BE STEEL UNLESS OTHERWISE APPROVED BY THE OWNER AND ALLOWED BY THE PROJECT PERMITS.
2. SHEET PILE SHALL INTERLOCK TO PROVIDE A REASONABLE SEAL BETWEEN SHEETS. MEASURES TO IMPROVE INTERLOCKING SEAL SHALL BE NON-TOXIC.
3. SHEET PILE DIMENSIONS, INCLUDING SHAPE, WEIGHT, AND LENGTH, SHALL BE SUFFICIENT TO PROVIDE COFFERDAM STABILITY THROUGHOUT CONSTRUCTION CONSIDERING CONSTRUCTION PERIOD HYDROLOGY AND RESULTING HYDRAULIC CONDITIONS.
4. SHEET PILE TOP ELEVATION SHALL PROVIDE A MINIMUM OF 1 FOOT OF FREEBOARD FOR THE CONSTRUCTION PERIOD HYDROLOGY AND RESULTING HYDRAULIC CONDITIONS.

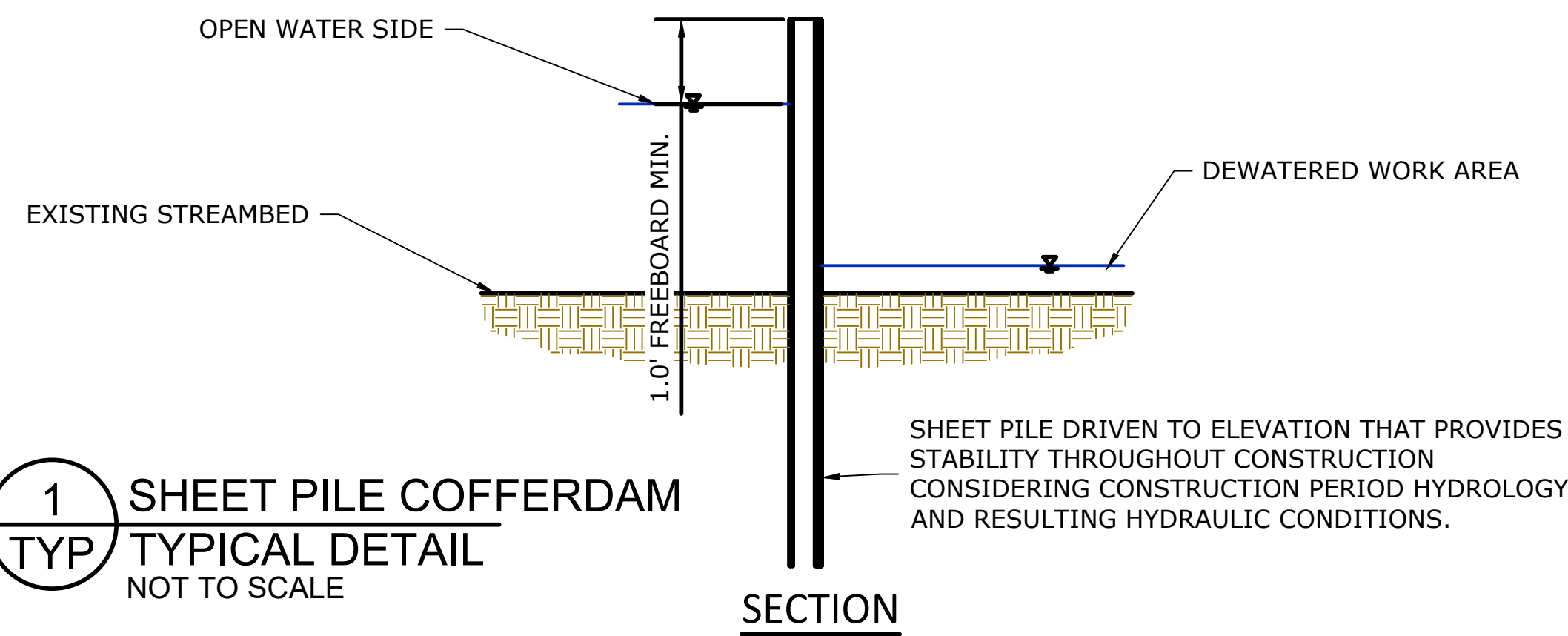
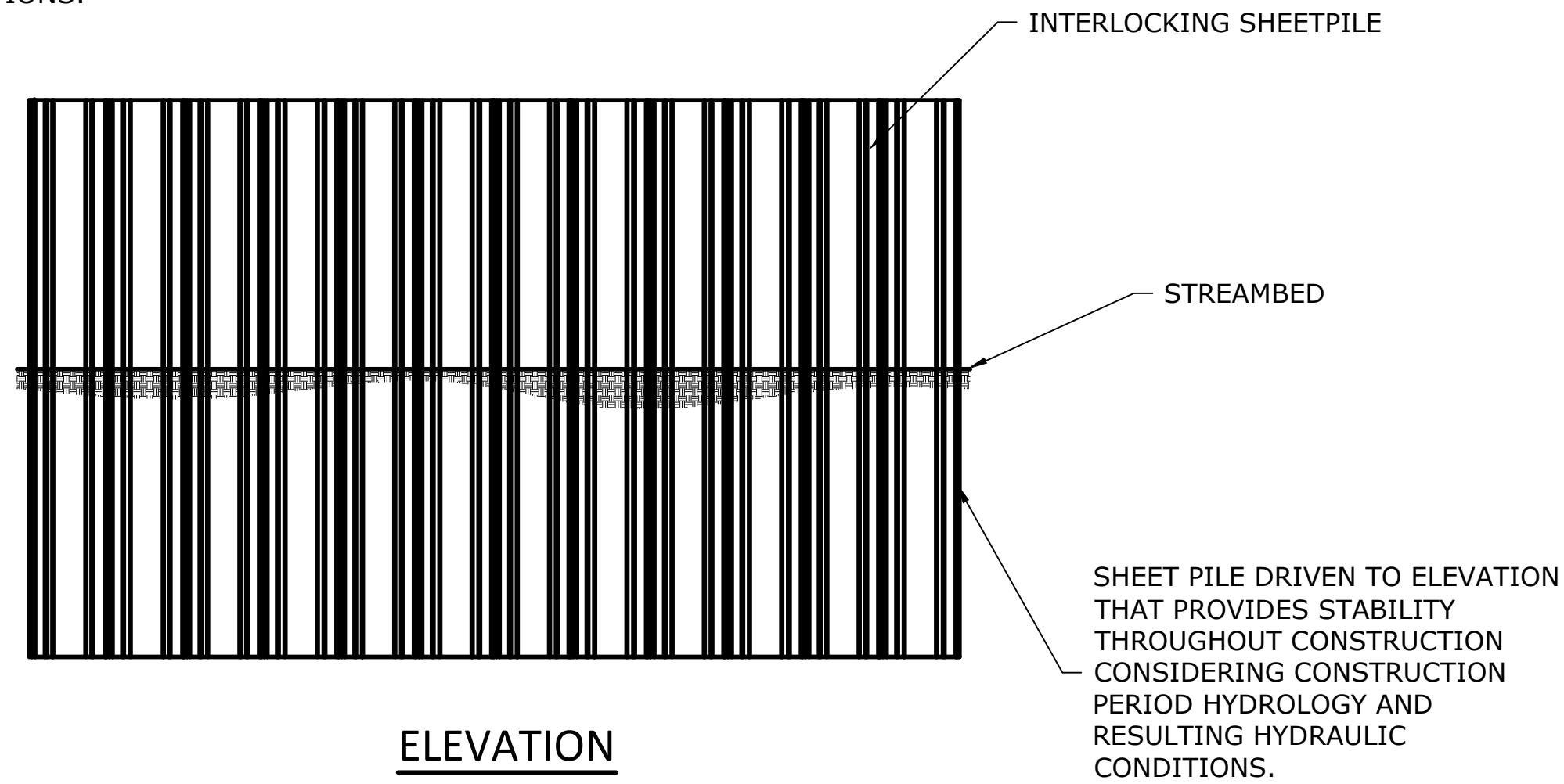

1 SHEET PILE COFFERDAM
TYP TYPICAL DETAIL
NOT TO SCALE

TEMPORARY COFFERDAM GENERAL NOTES:

1. TEMPORARY SHEET PILE IS A PRE-APPROVED METHOD OF ISOLATING CONSTRUCTION WATER FROM THE WATERWAY.
2. CONTRACTOR SHALL PROVIDE PUMPING SUFFICIENT FOR A NET INFLOW TO THE WORK AREA, AND DISCHARGE TURBID WATER TO UPLAND FLOODPLAIN.
3. COFFERDAM SHALL BE COMPLETELY REMOVED AFTER CONSTRUCTION IS COMPLETED AND TURBIDITY HAS BEEN REMOVED.

FUELING NOTES:

CONTRACTOR SHALL PROVIDE ADDITIONAL PROTECTION MEASURES AGAINST FUEL SPILLS WHEN REFUELING AREA IS WITHIN 150 FT OF A WETLAND AND THE RIVER. ADDITIONAL PROTECTION MEASURES SHALL CONSIST OF:

1. CONTAINMENT EQUIPMENT SIZED TO CONTAIN THE MOST LIKELY VOLUME OF FUEL SPILLED DURING A FUEL TRANSFER.
2. PORTABLE CONTAINMENT EQUIPMENT SHALL BE POSITIONED TO CATCH ANY FUEL SPILLS DUE TO OVERFILLING THE EQUIPMENT AND ANY OTHER SPILLS THAT MAY OCCUR AT OR NEAR THE FUEL FILLER PORT TO THAT EQUIPMENT DURING EACH REFUELING ACTIVITY.
3. PERSONNEL MUST ATTEND TO THE FUELING PROCESS TO ENSURE THAT ANY SPILLS WILL BE OF LIMITED VOLUME.

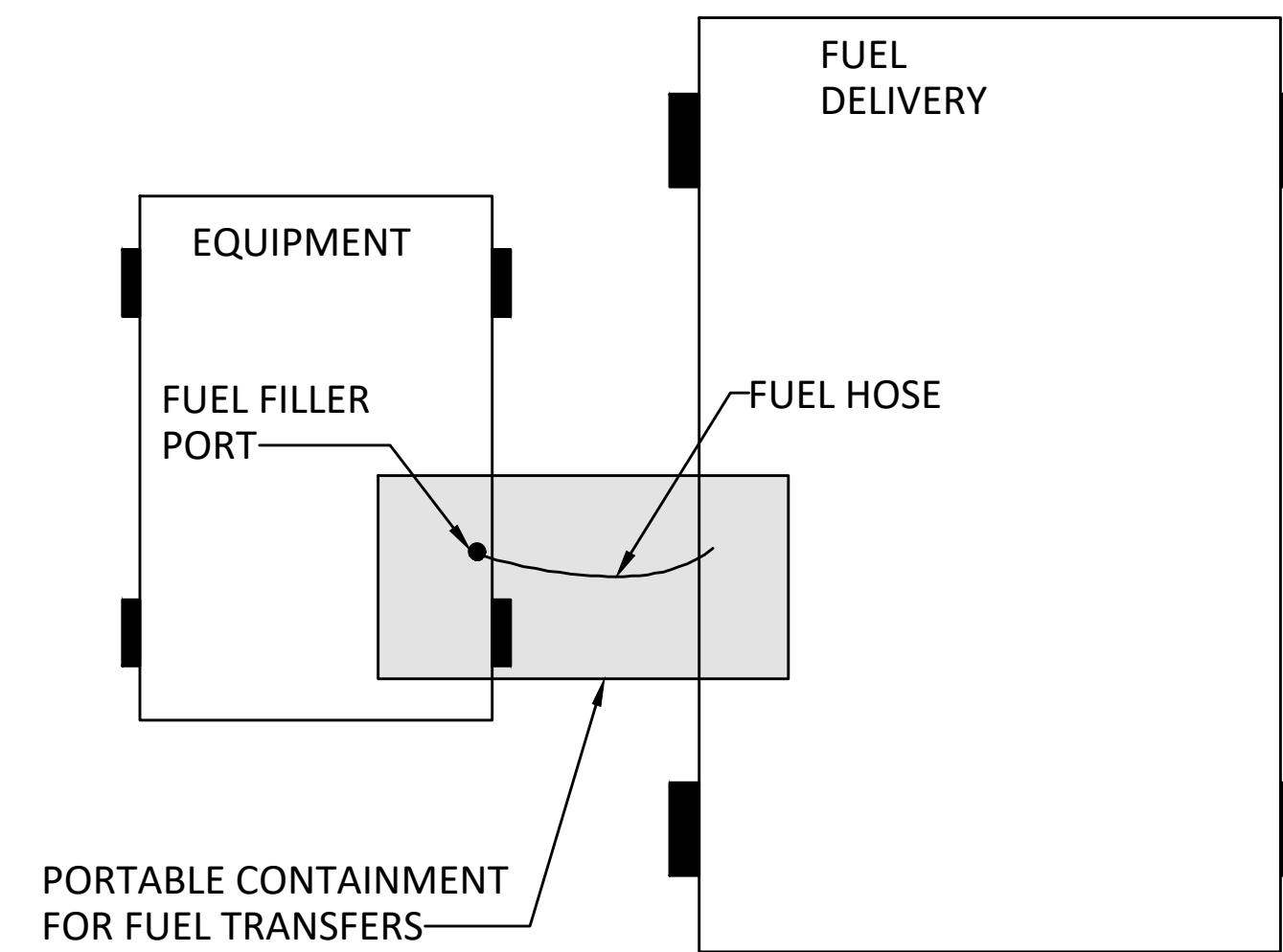

3 REFUELING TYPICAL DETAIL
TYP NOT TO SCALE

LAST SAVED DATE
2026-04-29
LAST SAVED BY
GREGGONWELL

CAD SYSTEM
AutoCAD 2015 (LMS TECH)
JFL LOWERCHIVAWA_AREA_G.DWG



ALWAYS THINK SAFETY

U.S. DEPARTMENT OF THE INTERIOR
BUREAU OF RECLAMATION
COLUMBIA PACIFIC NORTHWEST REGION
FCRPS HABITAT IMPROVEMENT PROGRAM
LOWER CHIVAWA RIVER PROJECT
PROJECT AREA G - PHASE 2
DRAFT FINAL DESIGN

DRAFT

CM DRAWN
LS, PB ACCEPTED
BOISE, ID APRIL 27, 2026

TEMPORARY COFFERDAM
DETAIL
SHEET 6

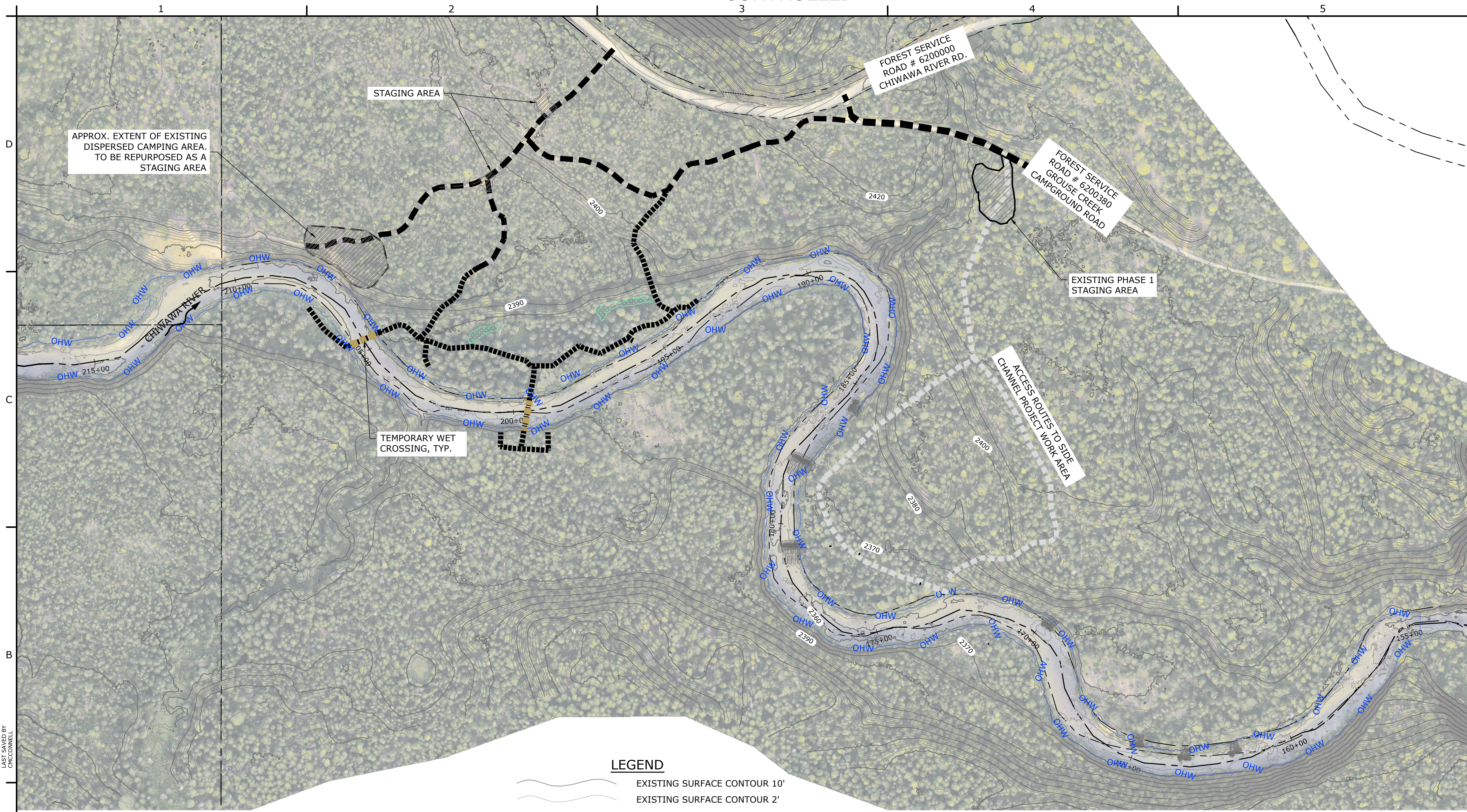

ALWAYS THINK SAFETY

U.S. DEPARTMENT OF THE INTERIOR
BUREAU OF RECLAMATION
COLUMBIA PACIFIC NORTHWEST REGION
FCRPS HABITAT IMPROVEMENT PROGRAM
LOWER CHIWAHA RIVER PROJECT
PROJECT AREA G - PHASE 2
DRAFT FINAL DESIGN

DRAFT











LAST SAVED DATE
2026-04-29
LAST SAVED BY
CIRCONEILL

CAD SYSTEM
AutoCAD 2015 (LMS TECH)
JFL LOWERCHIWAHA AREA_G.DWG

NOTES:

1. ALL TEMPORARY ACCESS AND HAUL ROUTES SHALL AVOID EXISTING MATURE TREES WHERE FEASIBLE. NO TREES >12" DBH MAY BE CLEARED FROM STAGING AREAS WITHOUT PRIOR APPROVAL BY THE OWNER.
2. TAXLOT INFORMATION IS APPROXIMATE
3. DEPICTED ACCESS ROUTES ARE APPROXIMATE AND WILL NEED TO BE COORDINATED WITH LANDOWNERS.
4. TEMPORARY ACCESS ROADS AND HAUL ROUTES SHALL UTILIZE EXISTING AND/OR DECOMMISSIONED FOREST ROADS WHERE FEASIBLE.
5. THE NUMBER OF WET CROSSINGS SHALL BE MINIMIZED TO THE EXTENT PRACTICABLE.
6. THE CONTRACTOR SHALL RESTORE ALL ACCESS ROUTES (INCLUDING EXISTING, REPURPOSED, AND NEW) TO THEIR ORIGINAL PRE-PROJECT CONDITION IN ACCORDANCE WITH OWNER REQUIREMENTS PRIOR TO DEMOBILIZING FROM THE PROJECT SITE.
7. ALL STAGING/STOCKPILE AREAS SHALL BE RESTORED TO THEIR ORIGINAL PRE-PROJECT CONDITION, IN ACCORDANCE WITH OWNER REQUIREMENTS, PRIOR TO DEMOBILIZING FROM THE PROJECT SITE.

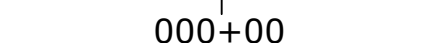
LEGEND

-  EXISTING SURFACE CONTOUR 10'
-  EXISTING SURFACE CONTOUR 2'
-  TAXLOTS
-  POTENTIAL ACCESS ROUTE - USE EXISTING
-  POTENTIAL ACCESS ROUTE - REPURPOSE FORMER
-  POTENTIAL ACCESS ROUTE - PIONEER NEW
-  SIDE CHANNEL PROJECT ACCESS ROUTES
-  CHIWAHA RIVER ALIGNMENT
-  ORDINARY HIGH WATER
-  EXISTING PHASE 1 LARGE WOOD STRUCTURE
-  DELINEATED WETLANDS (HAMER ENVIRONMENTAL)

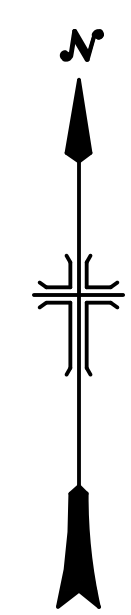
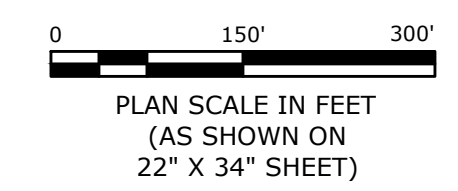

CM DRAWN
LS, PB ACCEPTED
BOISE, ID APRIL 27, 2026

EXISTING CONDITIONS,
SITE ACCESS AND
STAGING

SHEET 7



501 Portway Avenue, Suite 101
Hood River, OR 97031
541.386.9003
www.interfluve.com

ALWAYS THINK SAFETY
U.S. DEPARTMENT OF THE INTERIOR
BUREAU OF RECLAMATION
COLUMBIA PACIFIC NORTHWEST REGION
FCRPS HABITAT IMPROVEMENT PROGRAM
LOWER CHIWAWA RIVER PROJECT
PROJECT AREA G - PHASE 2
DRAFT FINAL DESIGN

DRAFT

CM
DRAWN
LS, PB
ACCEPTED
BOISE, ID APRIL 27, 2026

SITE OVERVIEW AND SHEET INDEX
SHEET 8

SHEET 8 OF 15

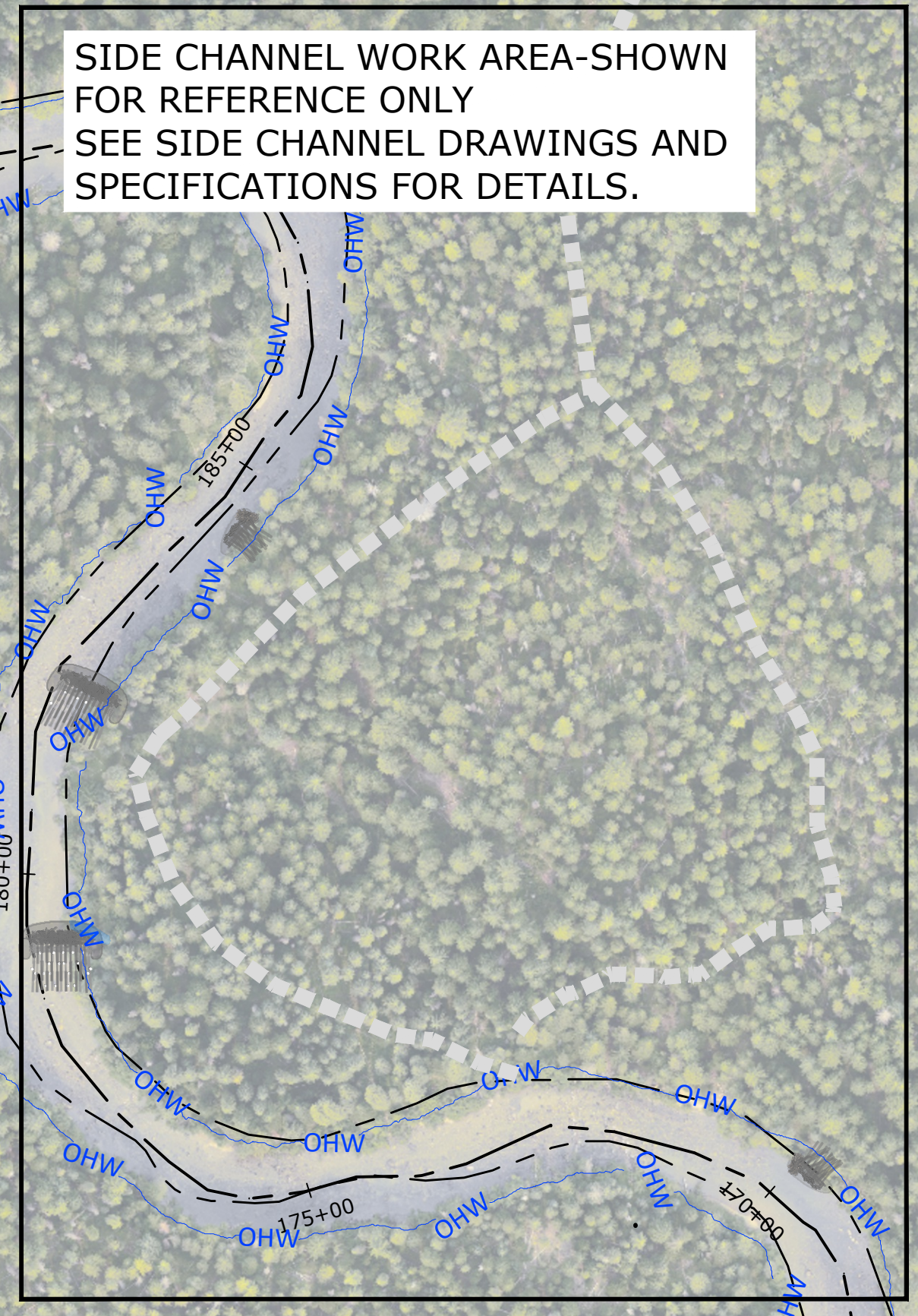
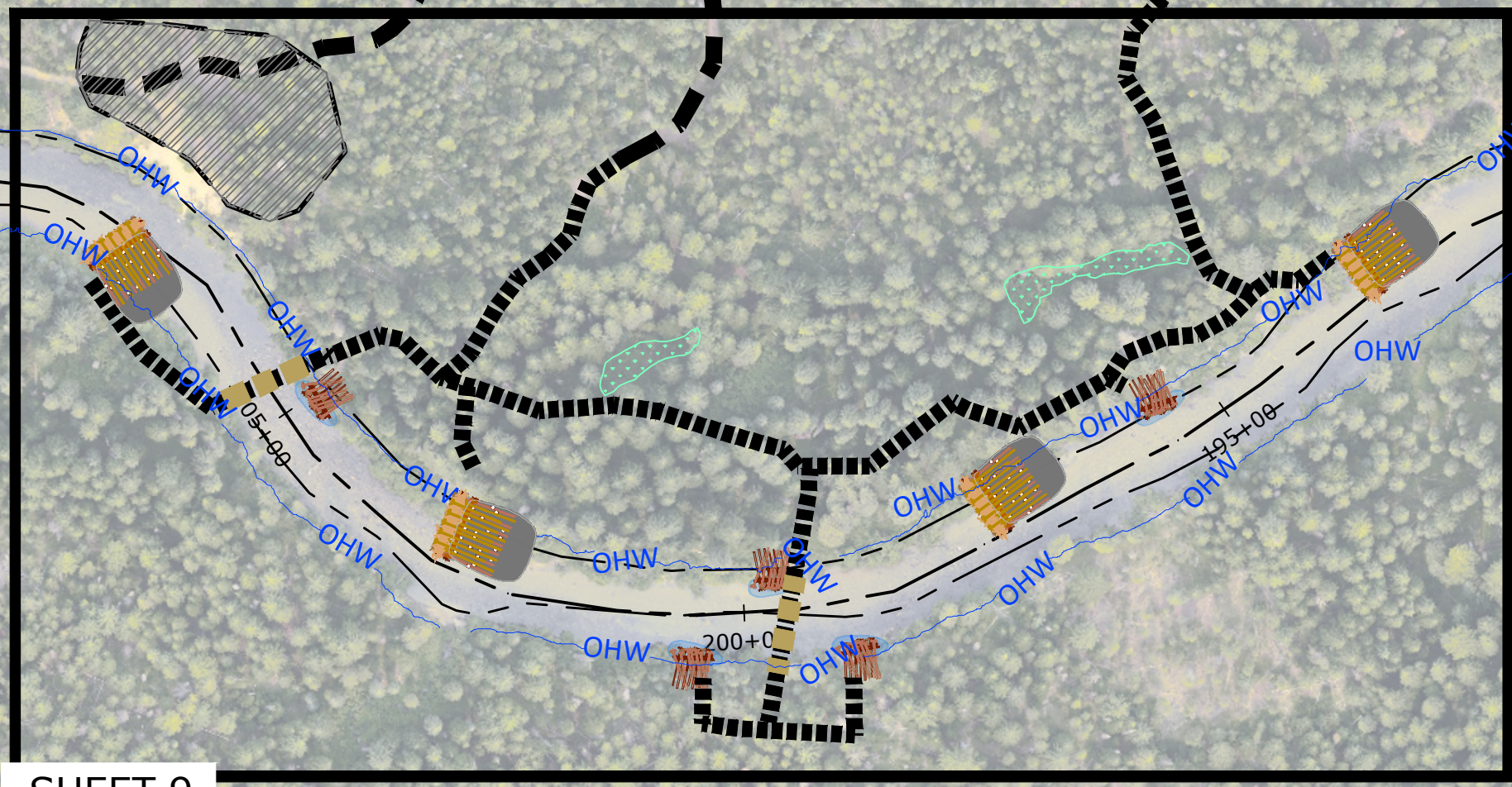
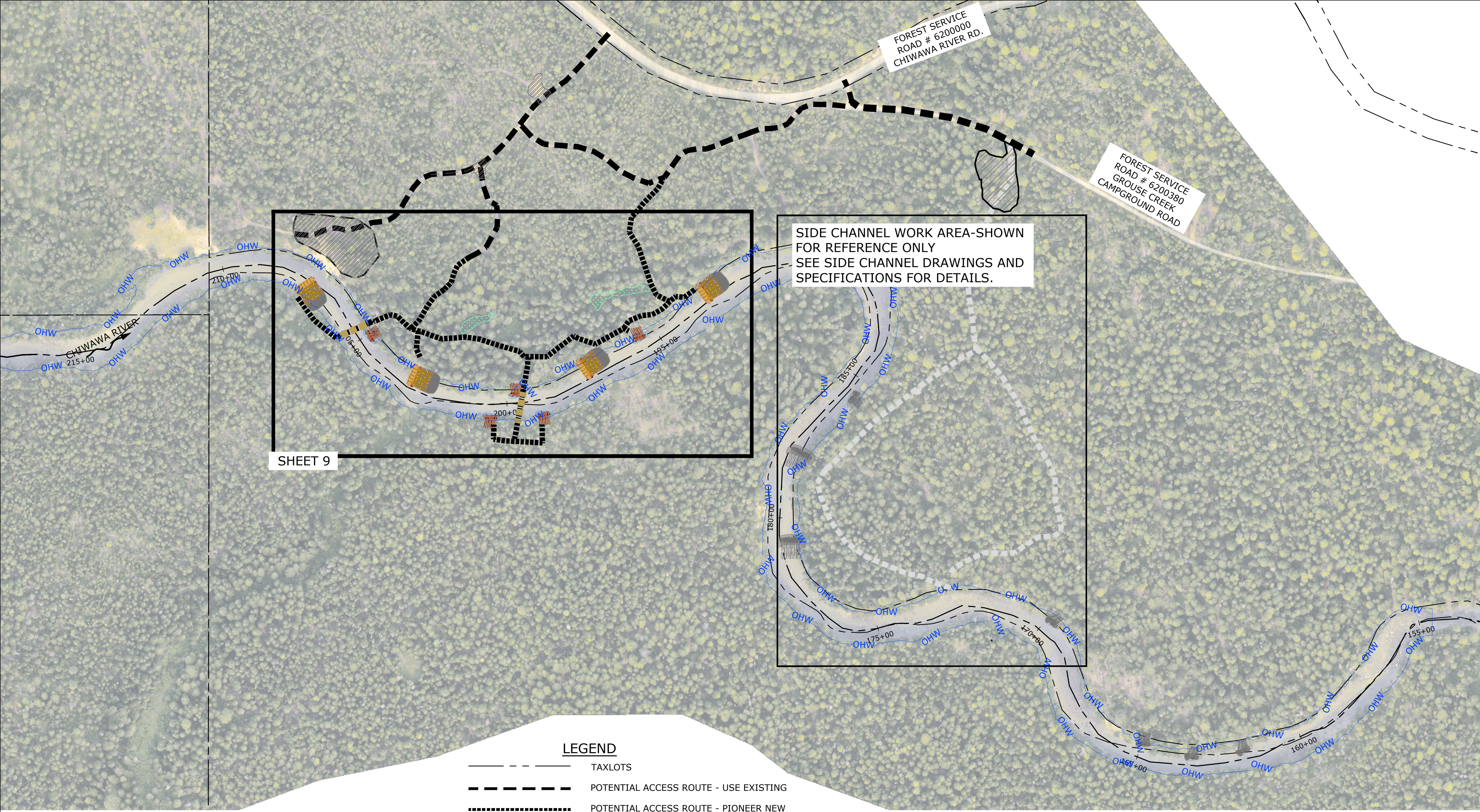

LEGEND

- TAXLOTS
- POTENTIAL ACCESS ROUTE - USE EXISTING
- POTENTIAL ACCESS ROUTE - PIONEER NEW
- SIDE CHANNEL ACCESS ROUTES
- ALIGNMENT
- ORDINARY HIGH WATER
- LARGE WOOD STRUCTURE (TYPE VARIES)
- EXISTING PHASE 1 LARGE WOOD STRUCTURE
- PROPOSED STAGING/STOCKPILE AREA
- DELINEATED WETLANDS (HAMER ENVIRONMENTAL)

NOTES:

1. ALL TREES AND OTHER NATIVE VEGETATION SLASH MATERIAL GENERATED DURING CLEARING OF ACCESS ROUTES AND STAGING/STOCKPILE AREAS SHALL BE SALVAGED IN ACCORDANCE WITH THE SPECIFICATIONS AND INCORPORATED INTO THE LARGE WOOD STRUCTURES AND OTHER HABITAT ELEMENTS AS A FIELD SET ITEM.
2. HELICOPTER-DELIVERED LARGE WOOD MATERIAL WILL BE STOCKPILED ADJACENT TO LARGE WOOD STRUCTURE LOCATIONS, OUTSIDE OF THE ORDINARY HIGH WATER BOUNDARY. TEMPORARY STOCKPILING OF MATERIALS DURING CONSTRUCTION SHALL AVOID IMPACTS TO MATURE TREES AND VEGETATION TO THE EXTENT PRACTICABLE.
3. TAXLOT INFORMATION IS APPROXIMATE

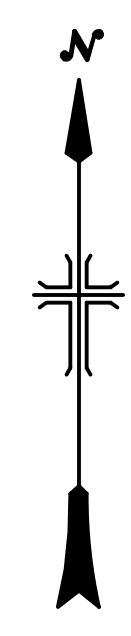
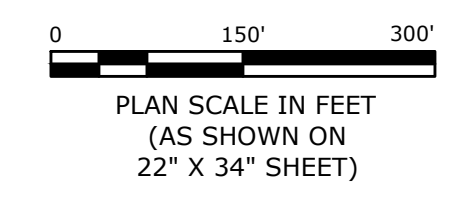

LAST SAVED DATE: 2026-04-29
DRAWN BY: CACCONWELL
CAD SYSTEM: AutoCAD 2015 (LMS TECH)
PROJECT: JFL LOWER CHIWAWA AREA_G.DWG

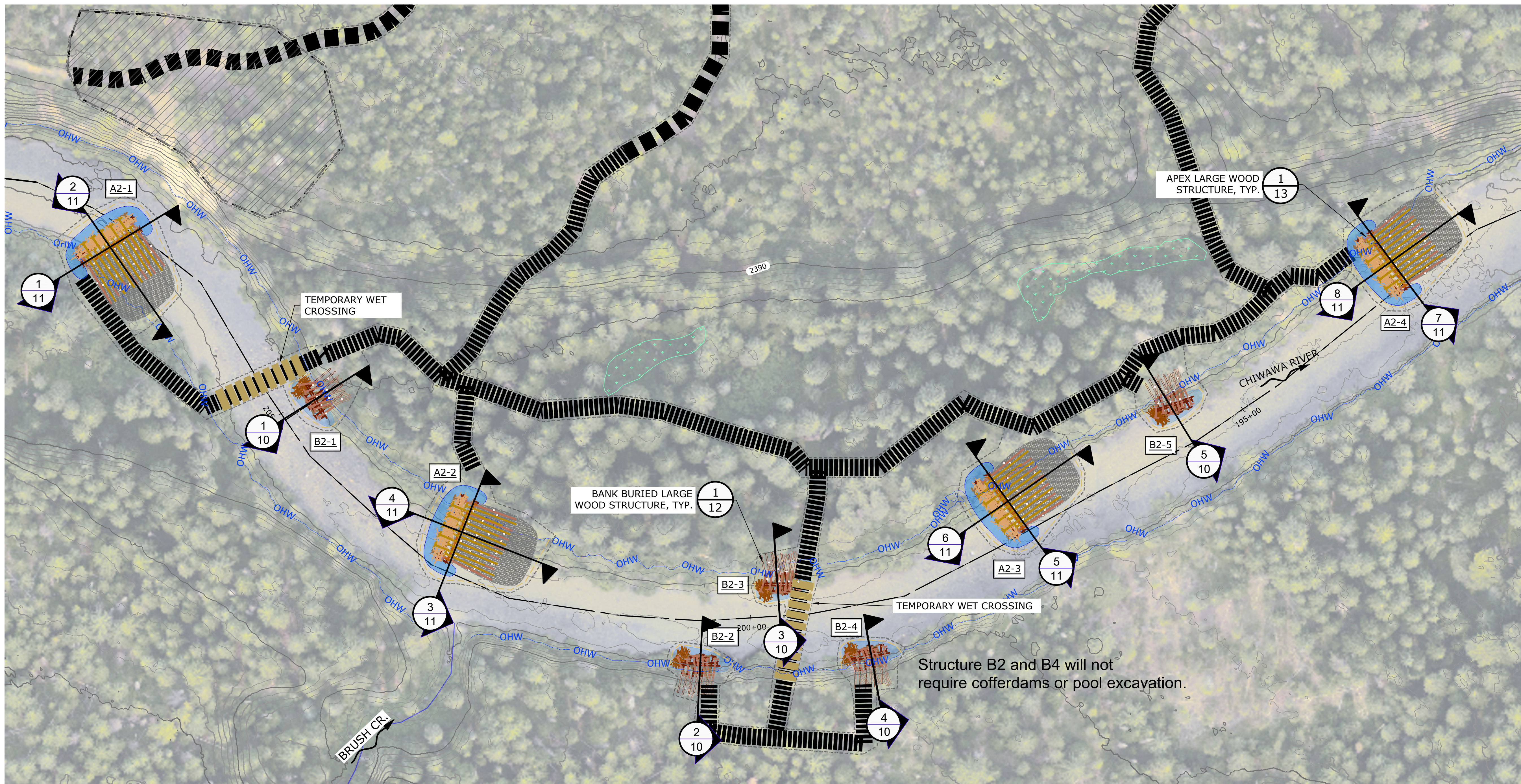

LAST SAVED DATE: 2026-04-29
 LAC SAVED BY: GRCOWELL
 CAD SYSTEM: AutoCAD 2015 (LMS TECH)
 FILE: JFL_LOWERCHITWAIVA_AREA_G.DWG

NOTES:

1. LARGE WOOD LAYOUT, LOCATIONS, AND ORIENTATIONS ARE APPROXIMATE AND WILL VARY DEPENDING ON SITE CONDITIONS AND THE DIMENSIONS OF WOOD RECEIVED.
2. ALL TEMPORARY ACCESS AND HAUL ROUTES SHALL AVOID EXISTING MATURE TREES WHERE FEASIBLE.
3. DEPICTED ACCESS ROUTES ARE APPROXIMATE AND WILL NEED TO BE COORDINATED WITH LANDOWNERS.
4. TEMPORARY ACCESS ROADS AND HAUL ROUTES SHALL UTILIZE EXISTING AND/OR DECOMMISSIONED FOREST ROADS WHERE FEASIBLE.
5. ALL TREES AND OTHER NATIVE VEGETATION SLASH MATERIAL GENERATED DURING CLEARING SHALL BE SALVAGED IN ACCORDANCE WITH THE SPECIFICATIONS AND INCORPORATED INTO THE LARGE WOOD STRUCTURES AND OTHER HABITAT ELEMENTS AS A FIELD SET ITEM.

LEGEND

- EXISTING SURFACE CONTOUR 10'
- EXISTING SURFACE CONTOUR 2'
- POTENTIAL ACCESS ROUTE - USE EXISTING
- POTENTIAL ACCESS ROUTE - PIONEER NEW
- ALIGNMENT
- ORDINARY HIGH WATER
- TEMPORARY COFFER DAM
- LIMITS OF DISTURBANCE
- LARGE WOOD STRUCTURE (TYPE VARIES)
- PROPOSED STAGING/STOCKPILE AREA
- DELINEATED WETLANDS (HAMER ENVIRONMENTAL)

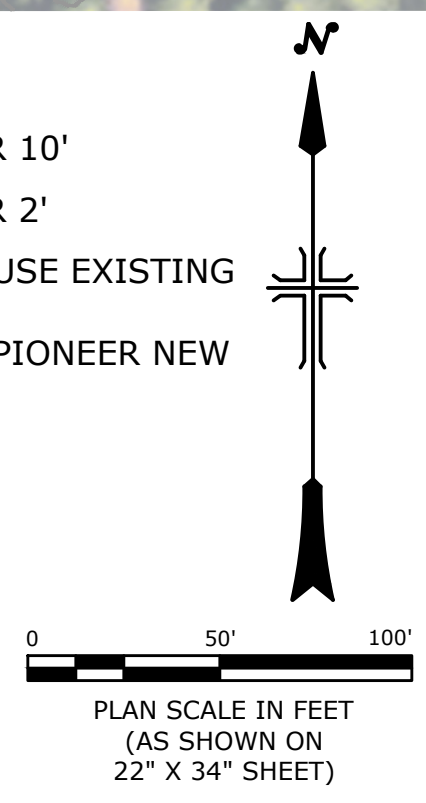

ESTIMATED CONSTRUCTION QUANTITIES

LARGE WOOD STRUCTURE	ROOTWAD LOGS	VERTICAL LOGS	SALVAGED TREES	SLASH	POOL EXCAVATION	TEMPORARY CUT/FILL	TEMPORARY COFFER DAM
	(EA)	(EA)	(EA)	(CY)	(CY)	(CY)	(LF)
B2-1	20	10	2	30	100	175	100
B2-2	20	0	2	30	100	280	85
B2-3	20	10	2	30	100	110	35
B2-4	20	0	2	30	100	310	85
B2-5	20	10	2	30	100	165	100
A2-1	40	24	15	100	300	450	215
A2-2	40	22	15	100	300	710	205
A2-3	40	22	15	100	300	620	220
A2-4	40	22	15	100	300	420	220
TOTAL	260	120	70	550	1700	3240	1265

BUREAU OF RECLAMATION

Yakama Nation Fisheries

inter-fluve
 501 Portway Avenue, Suite 101
 Hood River, OR 97031
 541.386.9003
 www.interfluve.com

ALWAYS THINK SAFETY

U.S. DEPARTMENT OF THE INTERIOR
 BUREAU OF RECLAMATION
 COLUMBIA PACIFIC NORTHWEST REGION
 FCRRS HABITAT IMPROVEMENT PROGRAM

LOWER CHITWAIVA RIVER PROJECT
PROJECT AREA G - PHASE 2
 DRAFT FINAL DESIGN

DRAFT

CM DRAWN

LS, PB ACCEPTED

BOISE, ID APRIL 27, 2026

PROPOSED CONDITIONS

SHEET 9

ALWAYS THINK SAFETY

U.S. DEPARTMENT OF THE INTERIOR
BUREAU OF RECLAMATION

COLUMBIA PACIFIC NORTHWEST REGION
FCRPS HABITAT IMPROVEMENT PROGRAM

LOWER CHIYAWA RIVER PROJECT
PROJECT AREA G - PHASE 2

DRAFT FINAL DESIGN

DRAFT

CM
DRAWN

LS, PB
ACCEPTED

BOISE, ID

APRIL 27, 2026

BANK BURIED CROSS SECTIONS

SHEET 10

SHEET 10 OF 15

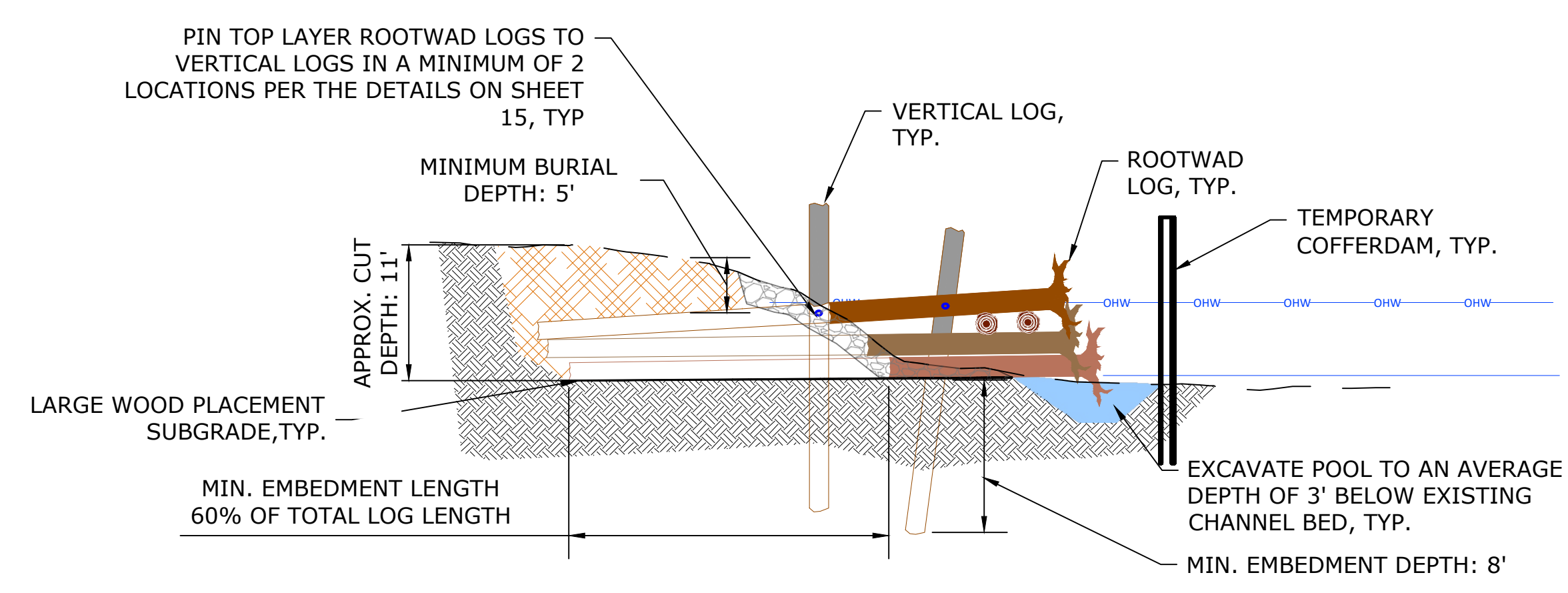

1
10 B2-1 -- BANK-BURIED LARGE WOOD STRUCTURE
1"=10'

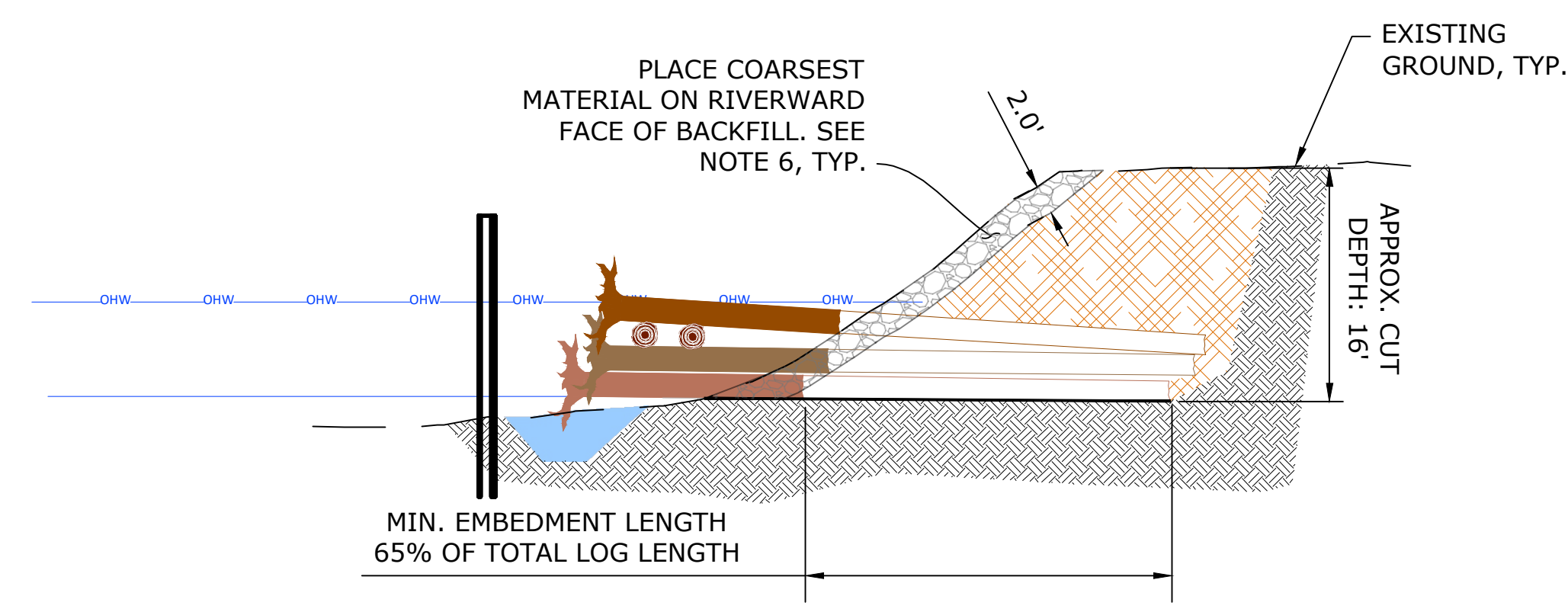

1
10 B2-2 -- BANK-BURIED LARGE WOOD STRUCTURE
1"=10'

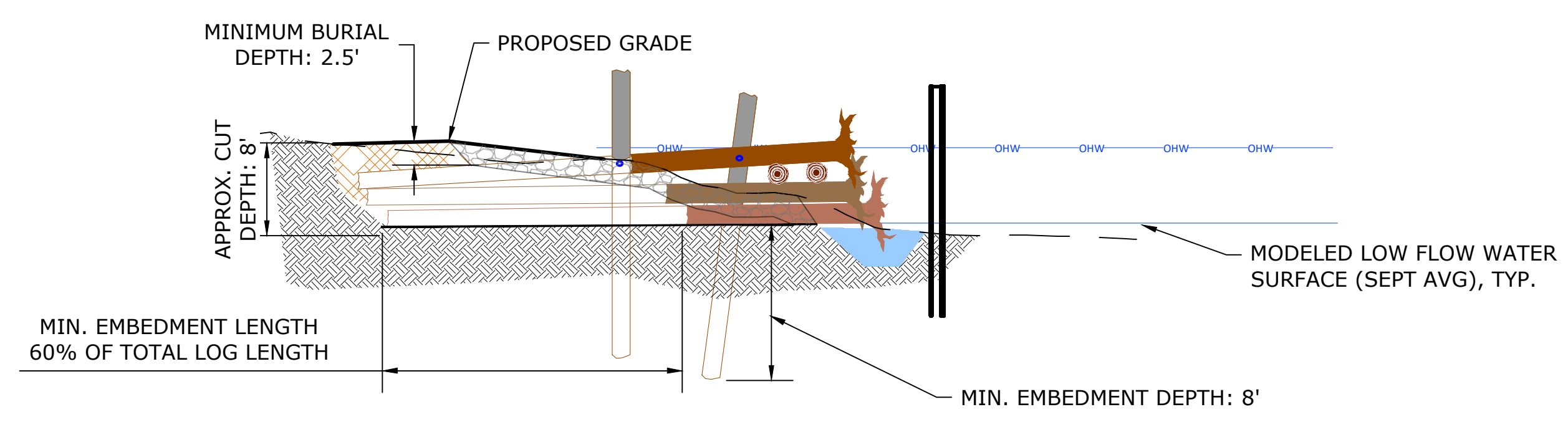

1
10 B2-3 -- BANK-BURIED LARGE WOOD STRUCTURE
1"=10'

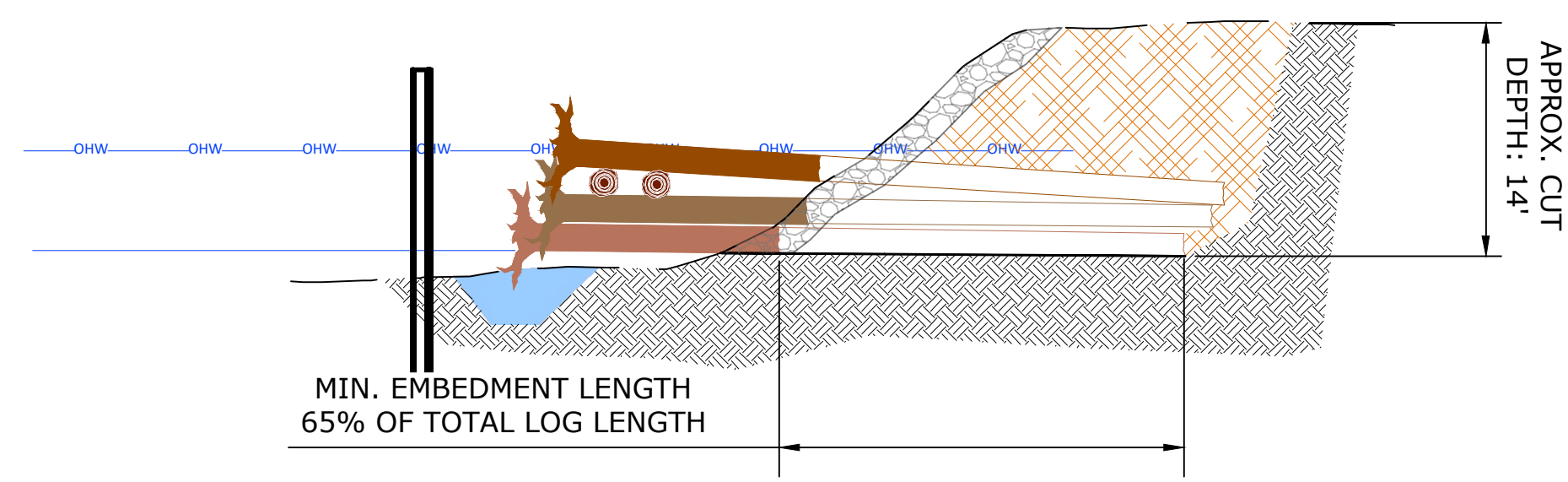

1
10 B2-4 -- BANK-BURIED LARGE WOOD STRUCTURE
1"=10'

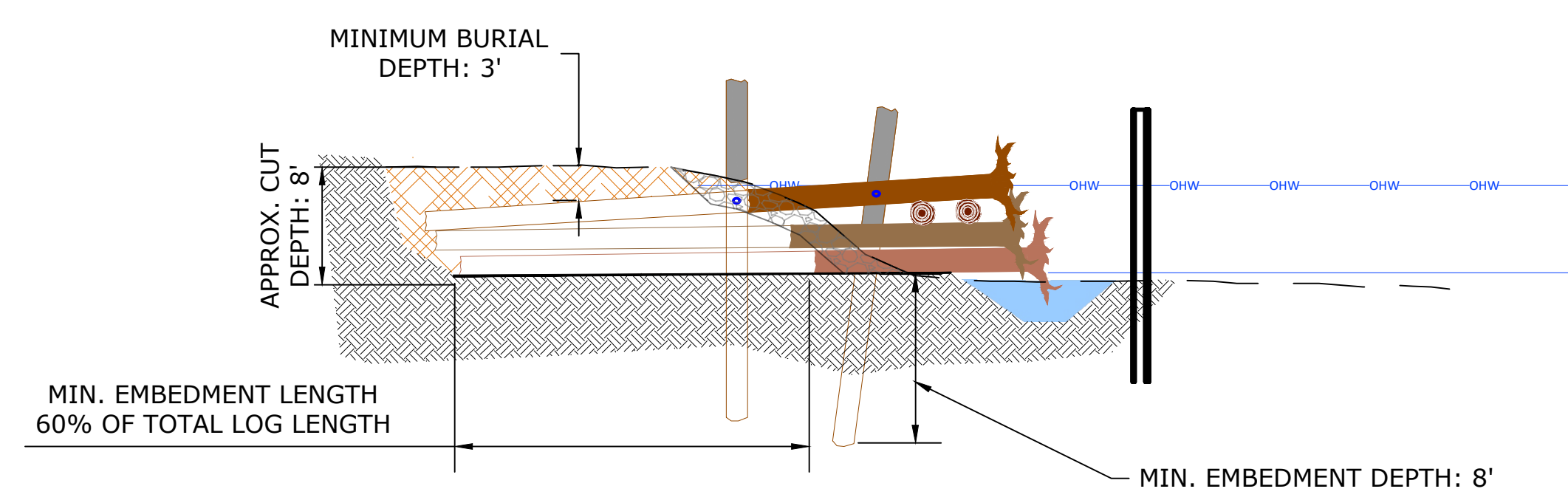

1
10 B2-5 -- BANK-BURIED LARGE WOOD STRUCTURE
1"=10'

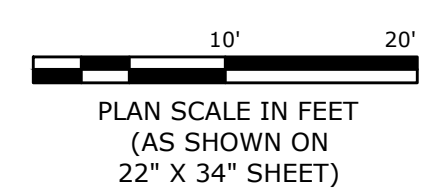

NOTES:

1. LARGE WOOD STRUCTURES SHALL BE CONSTRUCTED AS A FIELD SET ITEM, IN ACCORDANCE WITH THESE DRAWINGS AND THE SPECIFICATIONS. A TYPICAL CONFIGURATION OF BANK-BURIED LARGE WOOD STRUCTURE IS DEPICTED ON SHEET 12.
2. THE LAYOUT, CONFIGURATION AND LOCATIONS OF LARGE WOOD STRUCTURES ARE SUBJECT TO CHANGE, PENDING SITE CONDITIONS AT THE TIME OF CONSTRUCTION AND MATERIALS RECEIVED.
3. SALVAGED TREES AND SLASH ARE NOT DEPICTED IN THESE SECTION VIEWS FOR CLARITY.
4. VERTICAL LOG EMBEDMENT DEPTH SHALL BE MEASURED BELOW THE LARGE WOOD PLACEMENT SUBGRADE.
5. MINIMUM BURIAL DEPTH SHALL BE MEASURED FROM THE MIDPOINT OF THE BURIED PORTION OF THE TOP LAYER ROOTWAD LOG IN EACH STRUCTURE.
6. SALVAGED GRAVELS AND COBBLES FROM POOL AND SUBGRADE EXCAVATION SHALL BE STOCKPILED SEPARATELY AND SELECTIVELY USED ON THE RIVERWARD EDGE OF BACKFILL TO THE EXTENT PRACTICABLE.

LAST SAVED DATE
2026-04-29
LAST SAVED BY
LAC
DRAWN BY
SUCROWELL

CAD SYSTEM
AutoCAD 2015 (LMS TECH)
JFL LOWERCHIYAWA_AREA_G.DWG

NOTES:

1. LARGE WOOD STRUCTURES SHALL BE CONSTRUCTED AS A FIELD SET ITEM, IN ACCORDANCE WITH THESE DRAWINGS AND THE SPECIFICATIONS. A TYPICAL CONFIGURATION OF APEX LARGE WOOD STRUCTURE IS DEPICTED ON SHEET 13. THE RECOMMENDED CONSTRUCTION SEQUENCE FOR APEX LARGE WOOD STRUCTURE IS ON SHEET 14
2. THE LAYOUT, CONFIGURATION AND LOCATIONS OF LARGE WOOD STRUCTURES ARE SUBJECT TO CHANGE, PENDING SITE CONDITIONS AT THE TIME OF CONSTRUCTION AND MATERIALS RECEIVED.
3. SALVAGED TREES AND SLASH ARE NOT DEPICTED IN THESE SECTION VIEWS FOR CLARITY.
4. VERTICAL LOG EMBEDMENT DEPTH SHALL BE MEASURED BELOW THE LARGE WOOD PLACEMENT SUBGRADE.
5. SALVAGED GRAVELS AND COBBLES FROM POOL AND SUBGRADE EXCAVATION SHALL BE STOCKPILED SEPARATELY AND SELECTIVELY USED ON THE RIVERWARD EDGE OF BACKFILL TO THE EXTENT PRACTICABLE.



501 Portway Avenue, Suite 101
Hood River, OR 97031
541.366.9003
www.interfluv.com

ALWAYS THINK SAFETY

U.S. DEPARTMENT OF THE INTERIOR
BUREAU OF RECLAMATION
COLUMBIA PACIFIC NORTHWEST REGION
FCRPS HABITAT IMPROVEMENT PROGRAM
LOWER CHIWAWA RIVER PROJECT
PROJECT AREA G - PHASE 2
DRAFT FINAL DESIGN

DRAFT

CM DRAWN

LS, PB ACCEPTED

BOISE, ID APRIL 27, 2026

APEX SECTION AND PROFILE

SHEET 11

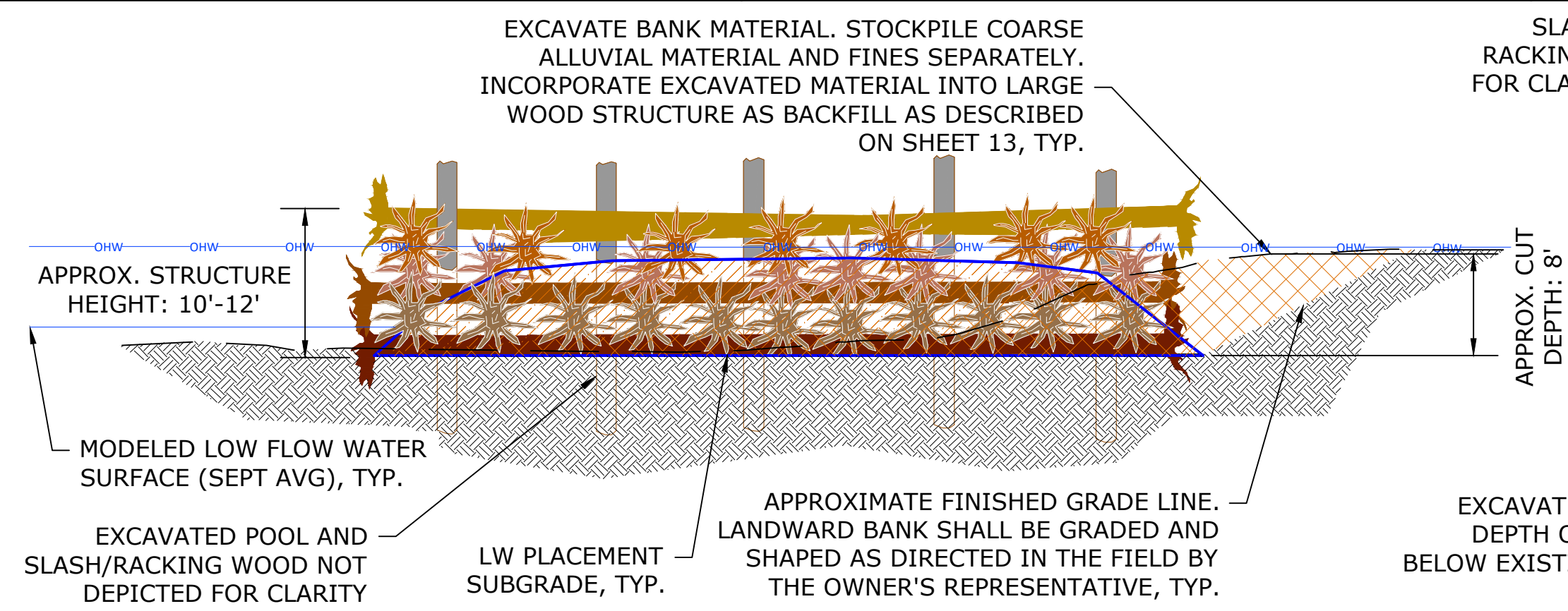

1 A2-1 - APEX LARGE WOOD STRUCTURE - SECTION VIEW
1"=10'

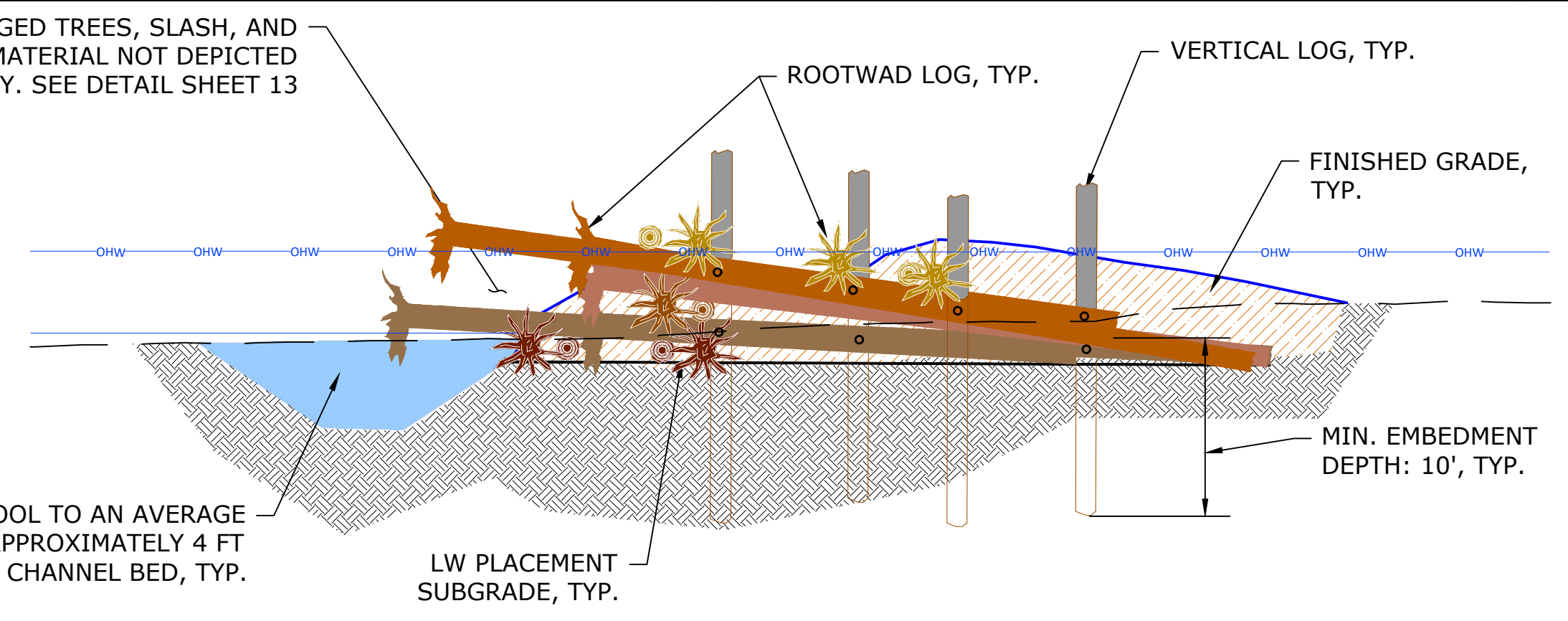

2 A2-1 - APEX LARGE WOOD STRUCTURE - PROFILE VIEW
1"=10'

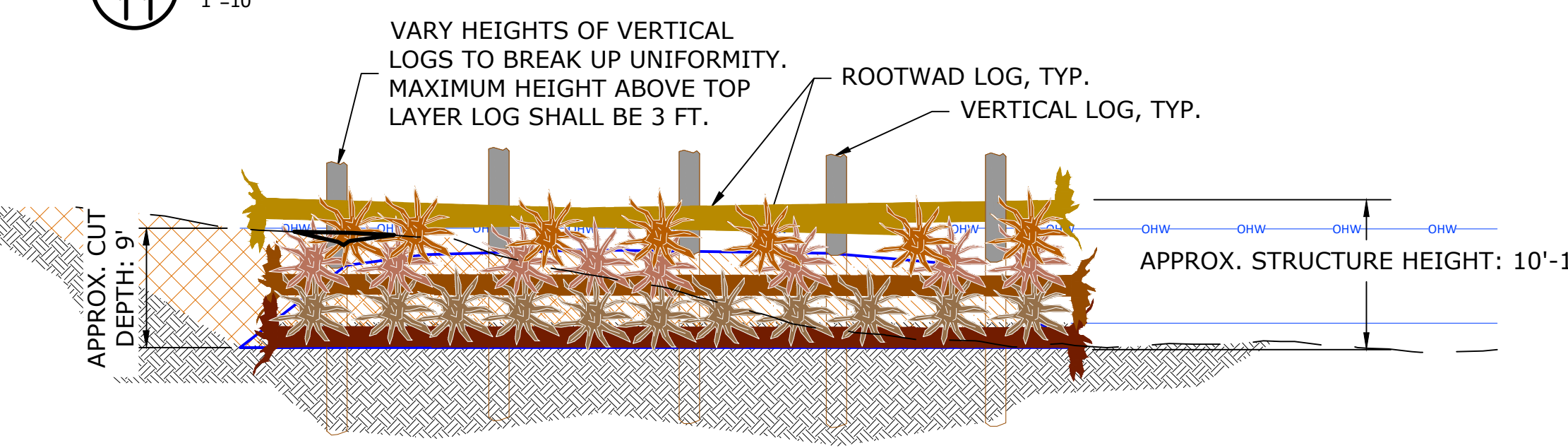

3 A2-2 - APEX LARGE WOOD STRUCTURE - SECTION VIEW
1"=10'

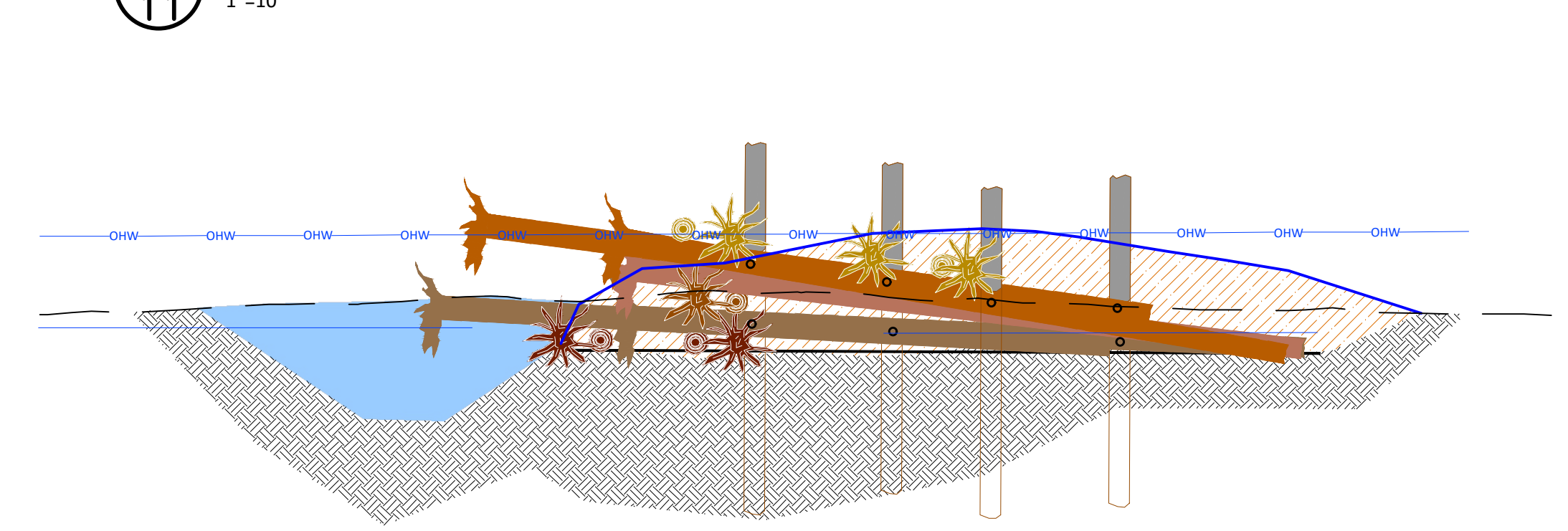

4 A2-2 - APEX LARGE WOOD STRUCTURE - PROFILE VIEW
1"=10'

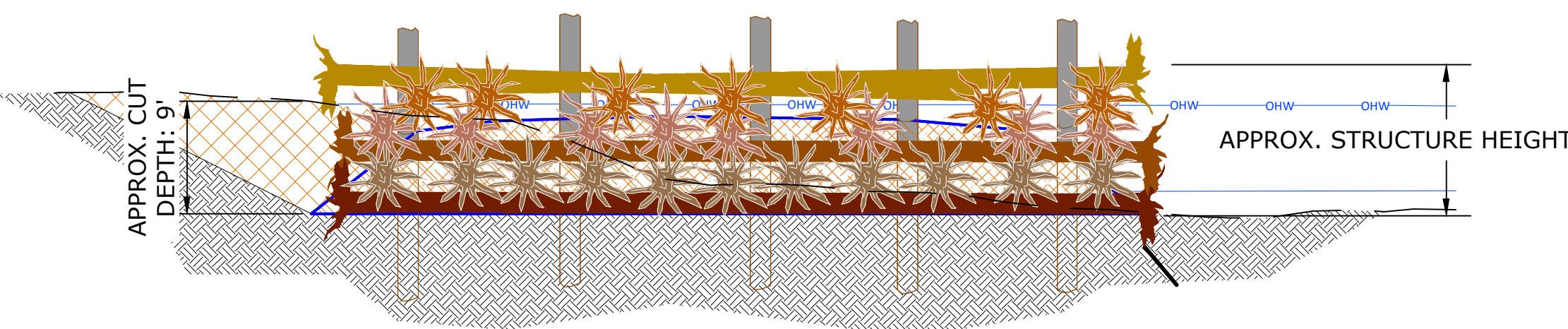

5 A2-3 - APEX LARGE WOOD STRUCTURE - SECTION VIEW
1"=10'

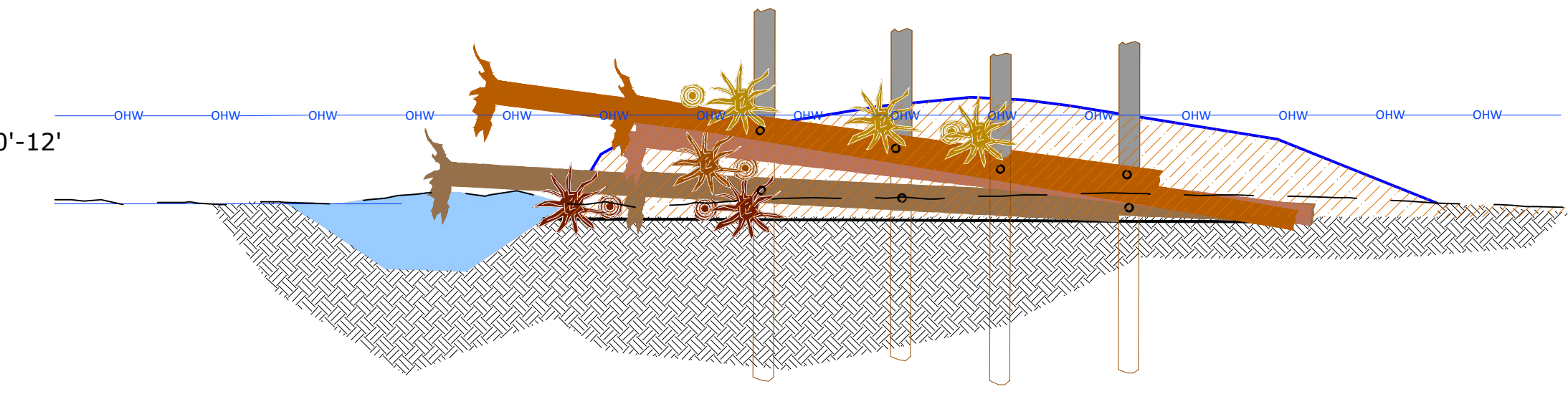

6 A2-3 - APEX LARGE WOOD STRUCTURE - PROFILE VIEW
1"=10'

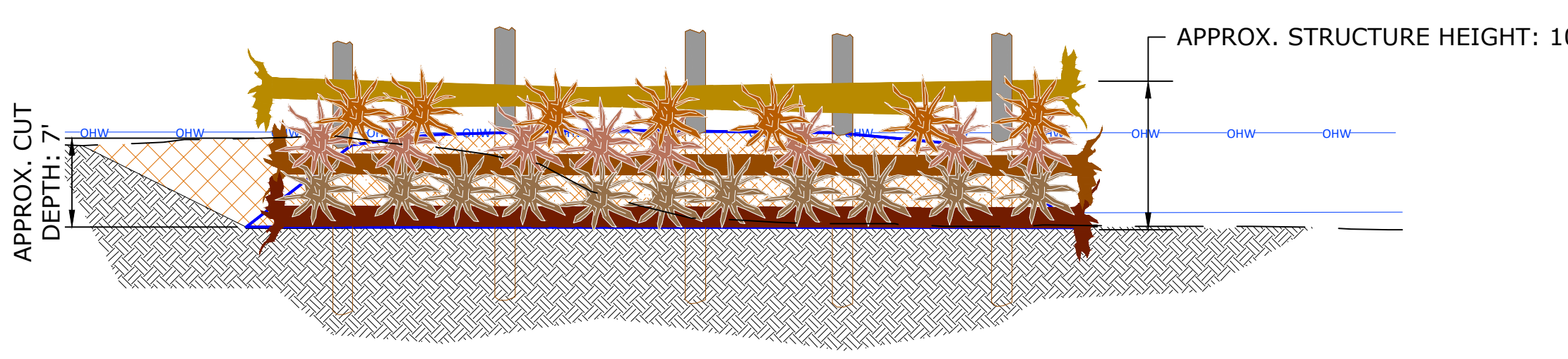

7 A2-4 - APEX LARGE WOOD STRUCTURE - SECTION VIEW
1"=10'

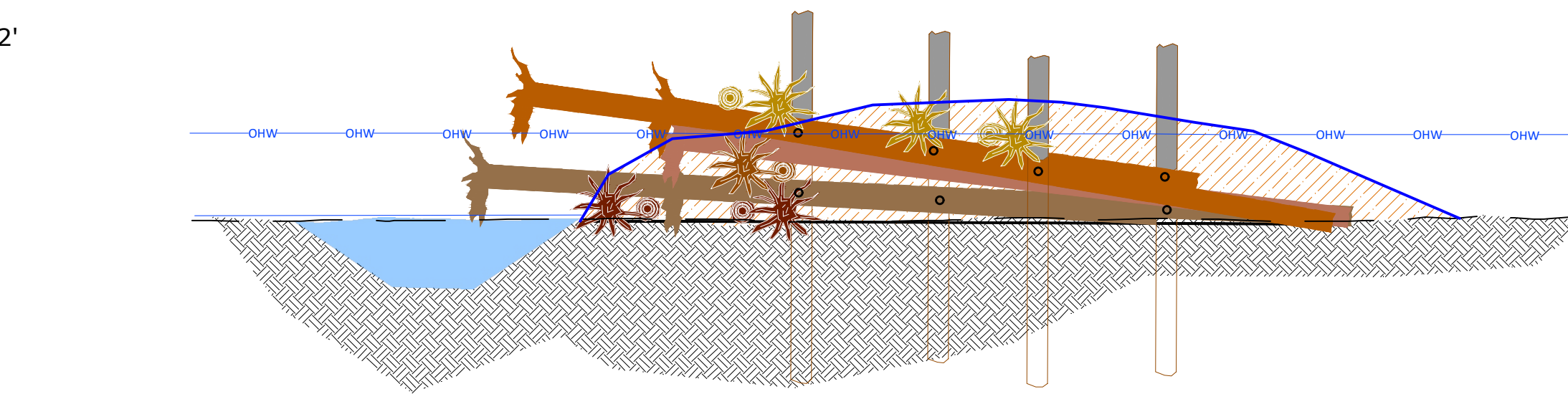

8 A2-4 - APEX LARGE WOOD STRUCTURE - PROFILE VIEW
1"=10'

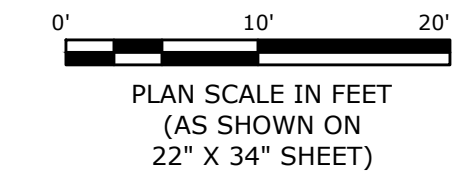

LAST SAVED DATE
2026-04-29
LAST SAVED BY
CUCONWELL

CAD SYSTEM
AutoCAD 2015 (LMS TECH)
JFL LOWERCHIWAWA_AREA_G.DWG

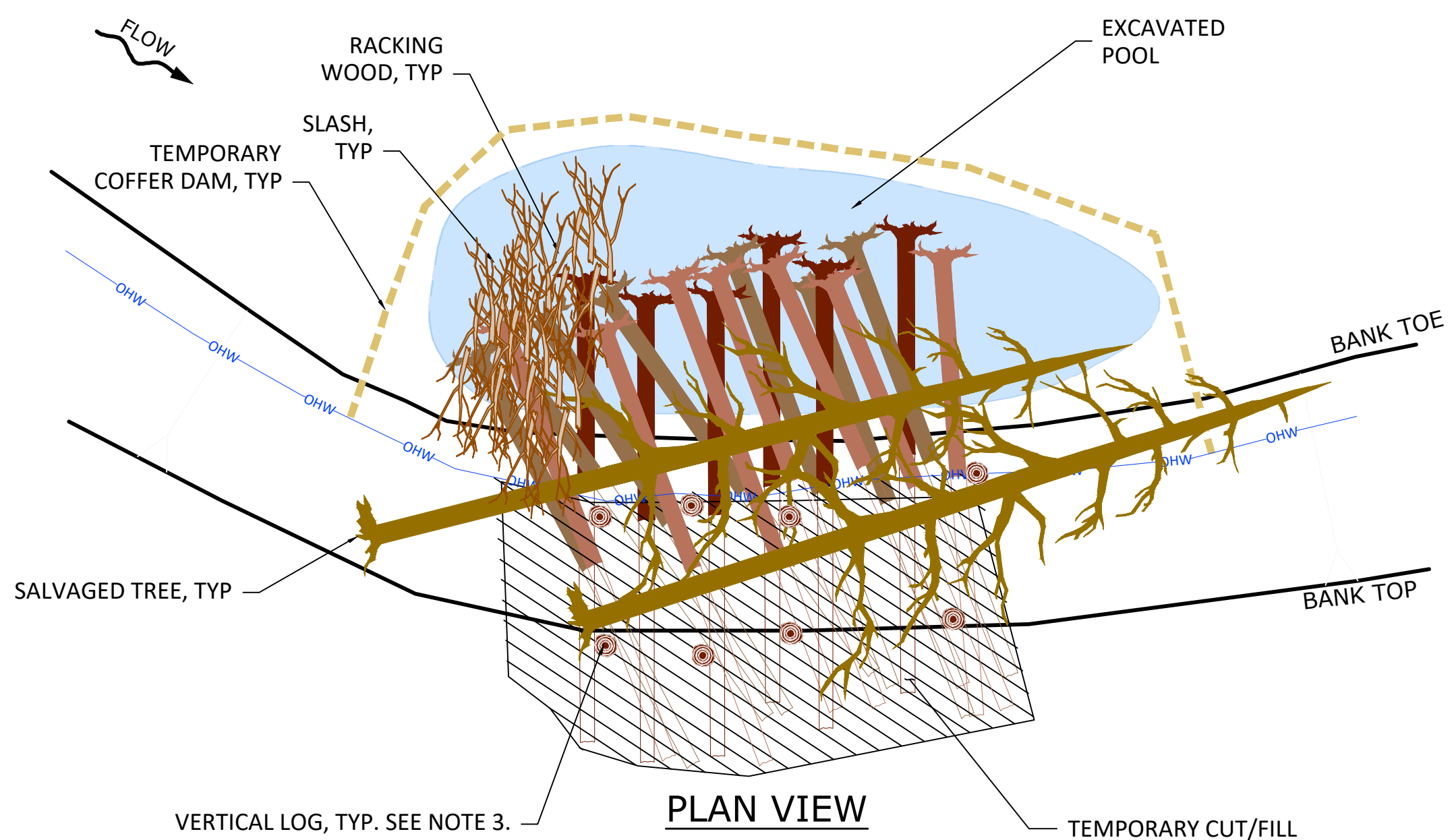

NOTES:

1. THE DEPICTED LARGE WOOD DETAILS ARE TYPICAL REPRESENTATIONS. THE EXACT LAYOUT, ORIENTATION, AND CONFIGURATION OF LARGE WOOD MATERIAL IS SUBJECT TO CHANGE BASED ON SITE SPECIFIC CONDITIONS AND THE LARGE WOOD MATERIAL RECEIVED..
2. WHOLE TREES AND SLASH SHALL BE SALVAGED AND INCORPORATED INTO THE LARGE WOOD STRUCTURES IN ACCORDANCE WITH THE SPECIFICATIONS AS A FIELD SET ITEM.
3. VERTICAL LOGS SHALL BE INSTALLED IN A PORTION OF THE BANK-BURIED LW STRUCTURES AS DEPICTED ON SHEET 10. EACH VERTICAL LOG SHALL HAVE A MINIMUM OF ONE (1) BOLTED CONNECTION TO A TOP LAYER ROOTWAD LOG PER THE DETAILS ON SHEET 15.
4. THE MINIMUM BURIAL DEPTHS SHALL BE MEASURED AS THE DISTANCE BETWEEN THE TOP OF THE TOP LAYER LOG AND FINISHED GRADE, AT THE MIDPOINT OF BURIED PORTION OF THE LOG.
5. MINIMUM EMBEDMENT DEPTHS SHALL BE MEASURED FROM THE LARGE WOOD SUBGRADE.
6. SALVAGED GRAVELS AND COBBLES FROM POOL AND SUBGRADE EXCAVATION SHALL BE STOCKPILED SEPARATELY AND SELECTIVELY USED ON THE RIVERWARD EDGE OF BACKFILL TO THE EXTENT PRACTICABLE.

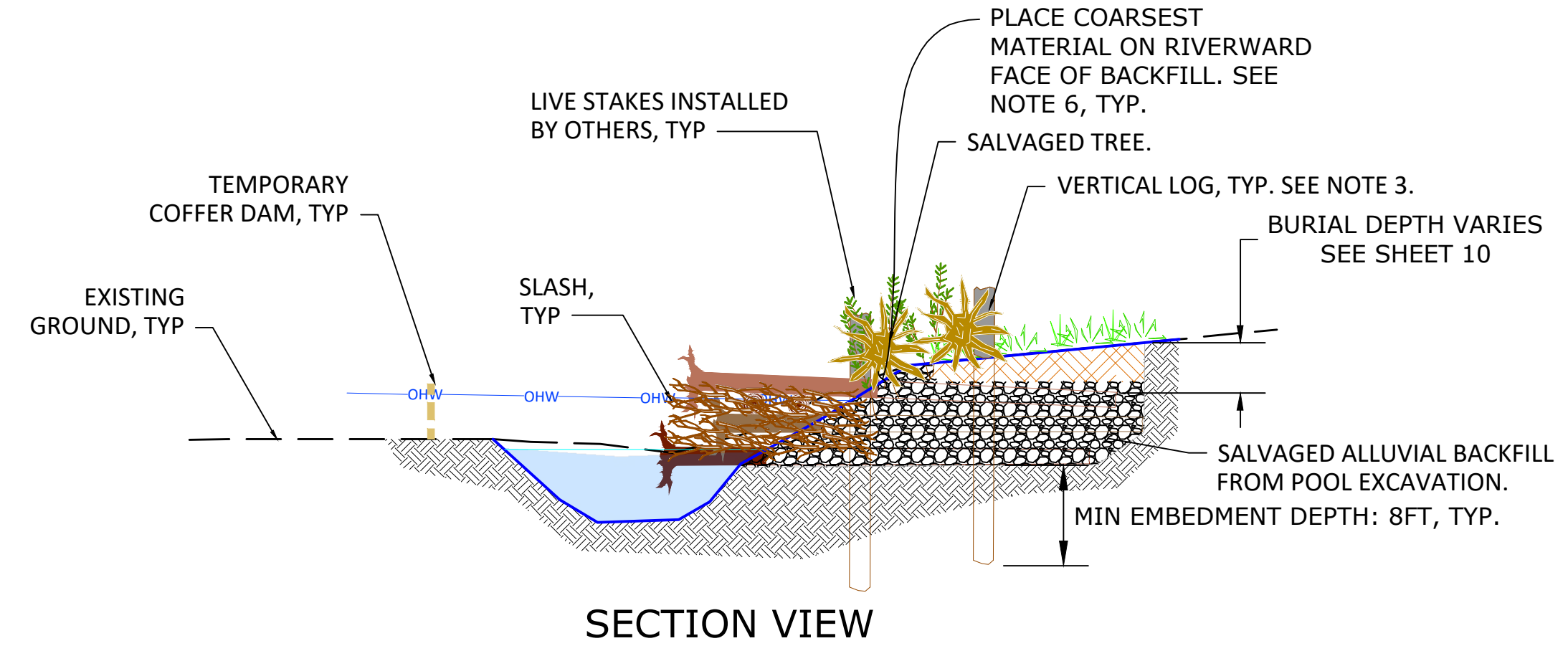

1 TYPICAL DETAIL – BANK-BURIED LARGE WOOD STRUCTURE
 12 NOT TO SCALE

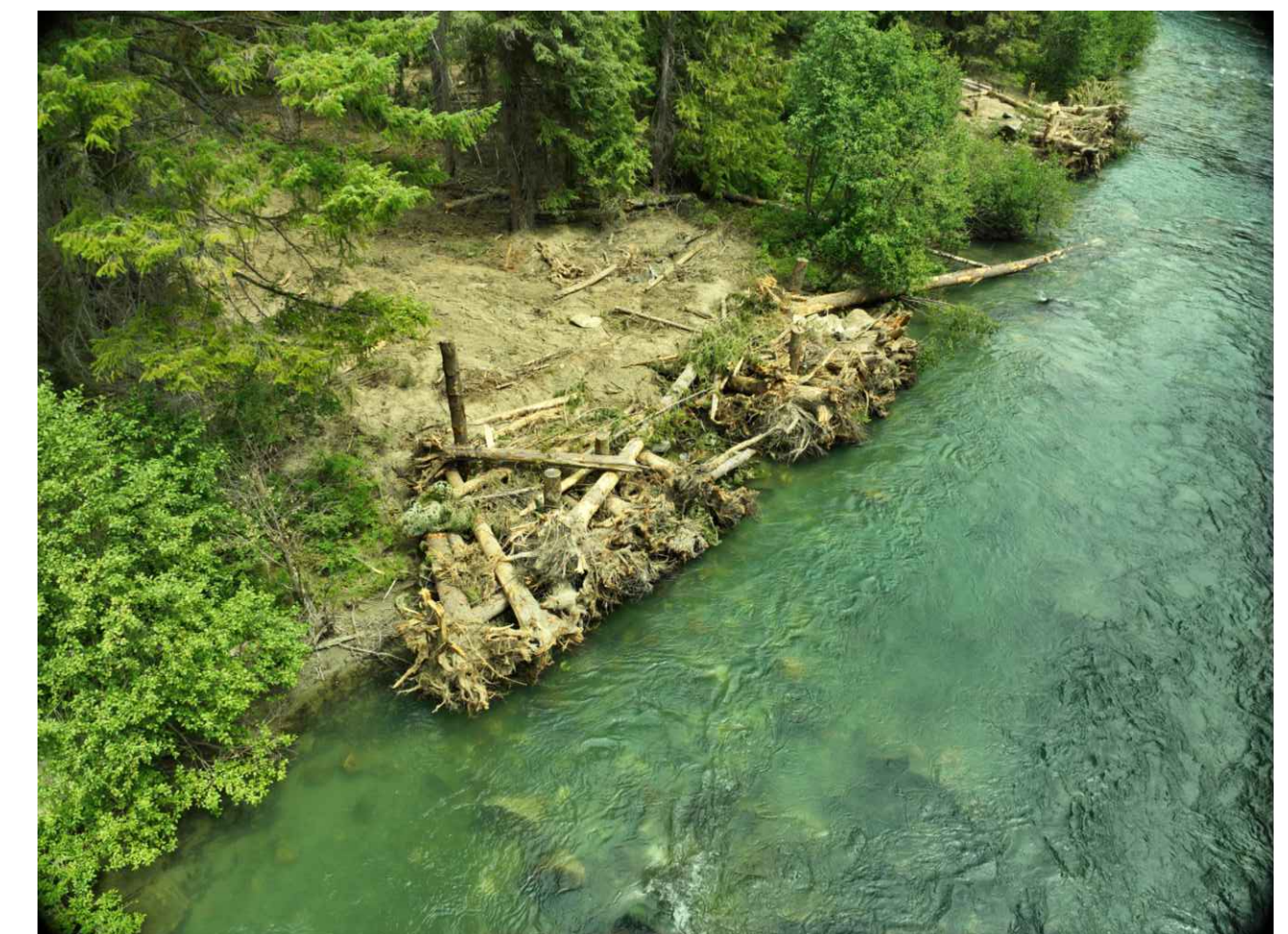

PHASE 1 CONSTRUCTED BANK-BURIED LARGE WOOD STRUCTURES

ALWAYS THINK SAFETY

U.S. DEPARTMENT OF THE INTERIOR
 BUREAU OF RECLAMATION
 COLUMBIA PACIFIC NORTHWEST REGION
 FCRRS HABITAT IMPROVEMENT PROGRAM
 LOWER CHIWAWA RIVER PROJECT
 PROJECT AREA G - PHASE 2
 DRAFT FINAL DESIGN

DRAFT

CM DRAWN
 LS, PB ACCEPTED
 BOISE, ID APRIL 27, 2026

TYPICAL DETAILS (1 OF 4)
 SHEET 12

LAST SAVED DATE
 2026-04-27
 LAST SAVED BY
 CIRCONEWELL

CAD SYSTEM
 AutoCAD 2015 (LMS TECH)
 JFL LOWERCHIWAWA-G_DETAILS_PH2.DWG



PHASE 1 CONSTRUCTED APEX LARGE WOOD STRUCTURE

TEMPORARY CUT/FILL ALONG EXISTING CHANNEL BANK (APPROXIMATE DEPICTION). FINISHED GRADE SHALL BE BLENDED INTO EXISTING TOPOGRAPHY AS DIRECTED BY THE OWNER'S REPRESENTATIVE.

SALVAGED TREES AND HEAVY SLASH INSTALLED AS DIRECTED BY THE OWNER'S REPRESENTATIVE.

EXISTING BANK/OHW LINE (APPROXIMATE DEPICTION)

ALLUVIAL BACKFILL MATERIAL. VOLUME IS DEPENDENT ON CONDITIONS DURING CONSTRUCTION

ROOTWAD LOG, TYP

VERTICAL LOG, TYP

BOLTED CONNECTIONS ON TOP LAYER ROOTWAD LOGS IN ACCORDANCE WITH THE DETAILS ON SHEET 15.

TEMPORARY COFFER DAM, TYP

EXCAVATED POOL

PLAN VIEW



TEMPORARY COFFER DAM, TYP

VERTICAL LOG, TYP

BOLTED CONNECTIONS ON TOP LAYER ROOTWAD LOGS PER THE DETAILS ON SHEET 12.

LIVE STAKES, INSTALLED BY OTHERS

SALVAGED ALLUVIAL MATERIAL PLACED ON TOP OF AND BEHIND LARGE WOOD STRUCTURE WHERE FEASIBLE. FINE MATERIAL SHALL BE PREFERENTIALLY PLACED IN THE TOP LAYERS TO FACILITATE PLANT GROWTH. PLANTING TO BE PERFORMED UNDER A SEPARATE CONTRACT.

ESTIMATED LOW WATER LINE

EXCAVATED POOL

MIN. EMBEDMENT DEPTH: 10FT, TYP.

SALVAGED WHOLE TREES AND HEAVY SLASH INSTALLED AS DIRECTED BY THE OWNER'S REPRESENTATIVE

BOLTED CONNECTIONS MAY BE REQUIRED ON LAYER 2 LOGS IN ACCORDANCE WITH THE SPECIFICATIONS.

SECTION VIEW

1 13 PILE SUPPORTED APEX LARGE WOOD STRUCTURE NOT TO SCALE

NOTES:

1. THE DEPICTED LARGE WOOD DETAILS ARE TYPICAL REPRESENTATIONS. THE EXACT LAYOUT, ORIENTATION, AND CONFIGURATION OF LARGE WOOD MATERIAL IS SUBJECT TO CHANGE BASED ON SITE SPECIFIC CONDITIONS AND THE LARGE WOOD MATERIAL RECEIVED.
2. WHOLE TREES AND SLASH SHALL BE SALVAGED AND INCORPORATED INTO THE LARGE WOOD STRUCTURES AS DIRECTED BY THE OWNER'S REPRESENTATIVE AND IN ACCORDANCE WITH THE SPECIFICATIONS AS A FIELD SET ITEM.
3. MINIMUM EMBEDMENT DEPTHS SHALL BE MEASURED FROM THE LARGE WOOD SUBGRADE.

LAST SAVED DATE 2026-04-27 LAC DRAWN BY CIRCONEILL

CAD SYSTEM AutoCAD 2015 (LMS TECH) JFL LOWERCHIVAWA-G_DETAILS_PH2.DWG



ALWAYS THINK SAFETY

U.S. DEPARTMENT OF THE INTERIOR BUREAU OF RECLAMATION

COLUMBIA PACIFIC NORTHWEST REGION

FCRPS HABITAT IMPROVEMENT PROGRAM

LOWER CHIWAWA RIVER PROJECT

PROJECT AREA G - PHASE 2

DRAFT FINAL DESIGN

DRAFT

CM DRAWN

LS, PB ACCEPTED

BOISE, ID

APRIL 27, 2026

TYPICAL DETAILS (2 OF 4)

SHEET 13

SHEET 13 OF 15

INSTALL VERTICAL LOGS PER THE SPECIFICATIONS. SEE NOTE "STEP 1, NOTE G" ON THIS SHEET.

EXCAVATE SUBGRADE AND STOCKPILE MATERIAL FOR BACKFILL

ATTACH LAYER 1 AND LAYER 2 LOGS TO VERTICAL LOGS USING THREADBAR CONNECTIONS PER THE DETAILS ON SHEET 15. NOT APPLICABLE IF VERTICAL LOGS ARE INSTALLED BY VIBRATORY PILE DRIVER

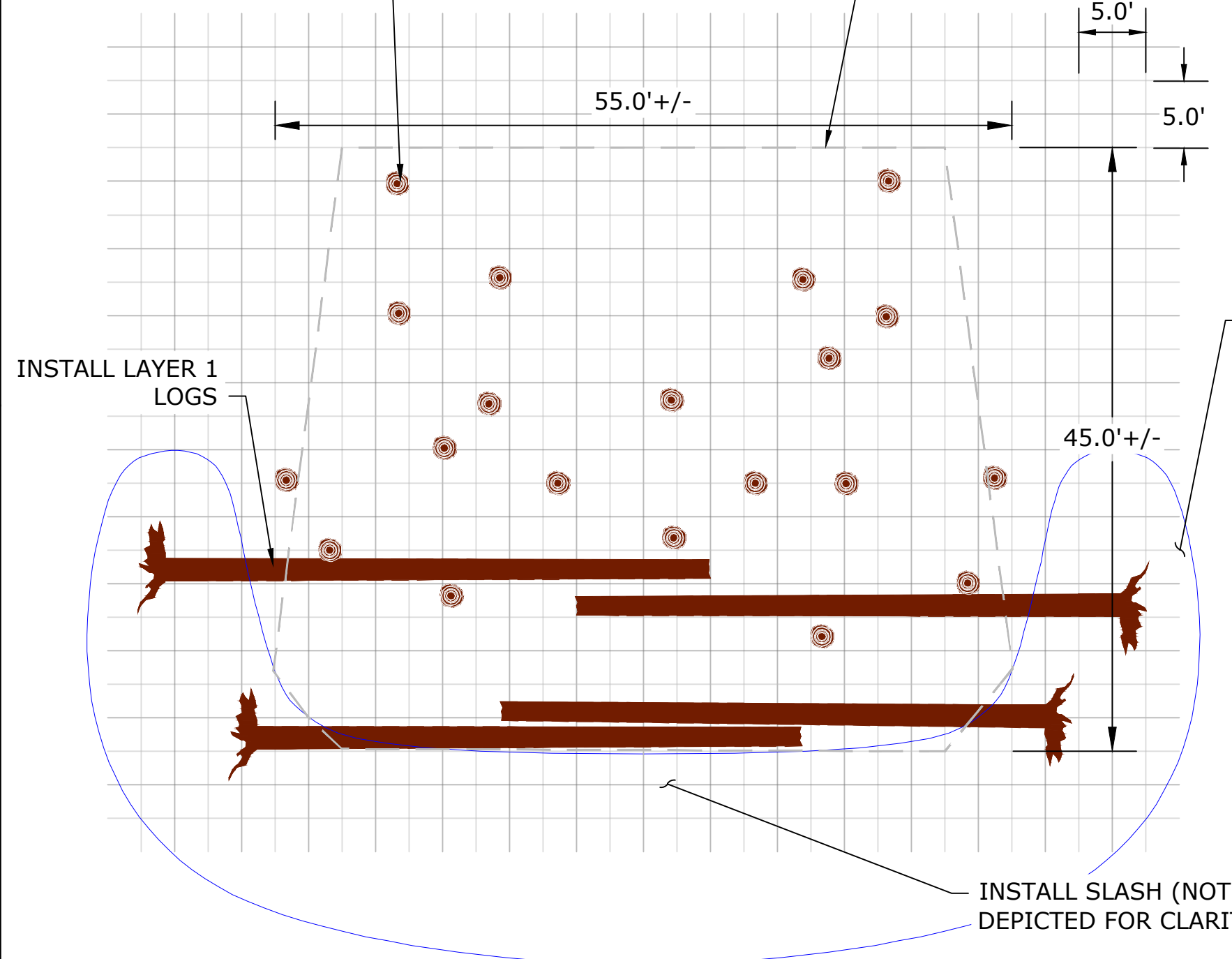

INSTALL LAYER 2 LOGS

EXCAVATE POOL AND STOCKPILE MATERIAL FOR BACKFILL (± 300 CY)

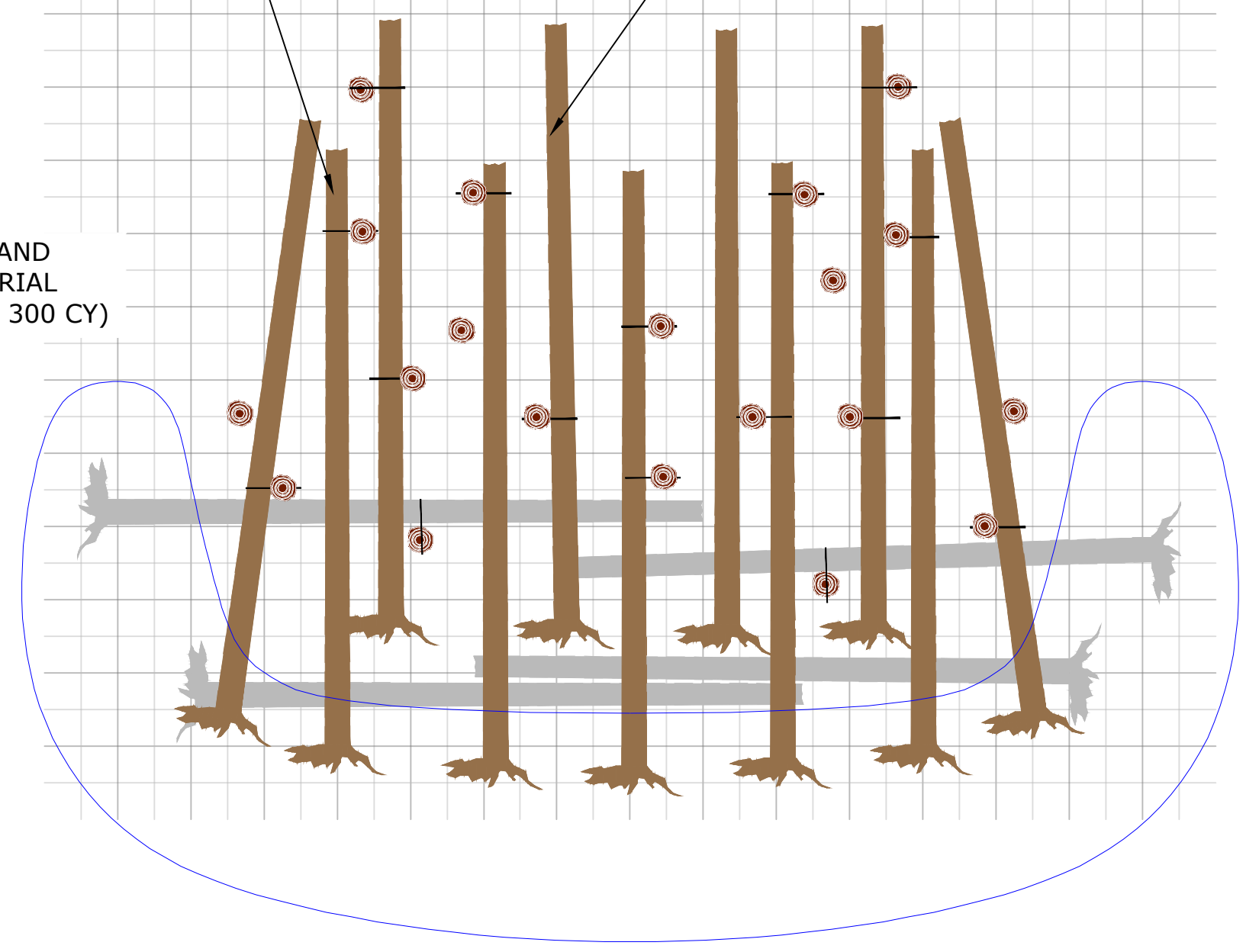

STEP 1: EXCAVATE WORK AREA, INSTALL LAYER 1 LOGS, AND VERTICAL LOGS

STEP 2: INSTALL LAYER 2 LOGS

SUGGESTED CONSTRUCTION SEQUENCING NOTES

- STEP 1: EXCAVATE WORK AREA, INSTALL LAYER 1 LOGS, AND VERTICAL LOGS
A. ISOLATE WORK AREA IN ACCORDANCE WITH THE CONTRACT DOCUMENTS AND APPLICABLE PERMIT CONDITIONS. WORK AREA ISOLATION AND FISH SALVAGE MUST BE COMPLETED PRIOR TO BEGINNING LARGE WOOD STRUCTURE CONSTRUCTION.
B. EXCAVATE WORK AREA. STOCKPILE EXCAVATED MATERIAL IN ACCORDANCE WITH THE SPECIFICATIONS.
C. EXCAVATE SUBGRADE AND STOCKPILE MATERIAL FOR BACKFILL. VOLUME VARIES BY SITE.
D. EXCAVATE POOL AS DIRECTED BY THE OWNER'S REPRESENTATIVE (± 300 CY).
E. INSTALL LAYER 1 LOGS AND SLASH (NOT DEPICTED) AS DIRECTED BY THE OWNER'S REPRESENTATIVE.
F. INSTALL VERTICAL LOGS BY VIBRATORY PILE DRIVER IN ACCORDANCE WITH THE SPECIFICATIONS. A MINIMUM OF THREE "TEST PILES" SHALL BE INSTALLED AT EACH LWS LOCATION PRIOR TO PLACING LAYER 2 LOGS. INSTALLED VERTICAL LOGS ARE SUBJECT TO PULLOUT RESISTANCE TESTING IN ACCORDANCE WITH SHEET 15. IF "TEST PILES" ARE DEEMED SUITABLE, ALTERNATE SEQUENCING OF VERTICAL LOG INSTALLATION MAY BE ALLOWED WITH APPROVAL BY THE OWNER'S REPRESENTATIVE.
G. IF INSTALLATION BY VIBRATORY PILE DRIVER IS DEEMED INFEASIBLE, USE ALTERNATE METHOD DESCRIBED BELOW WITH APPROVAL BY THE OWNER'S REPRESENTATIVE.
G.1. ALTERNATE VERTICAL LOG INSTALLATION METHOD:
G.1.1. EXCAVATE TO A MINIMUM DEPTH OF 3 FT BELOW THE SUBGRADE ELEVATION AT THE VERTICAL LOG LOCATIONS IDENTIFIED BY THE OWNER'S REPRESENTATIVE.
G.1.2. DRIVE VERTICAL LOGS TO A MINIMUM DEPTH OF 3 FT BELOW THE BOTTOM OF THE EXCAVATED AREA.
G.1.3. BACKFILL AROUND THE INSTALLED VERTICAL LOG USING SALVAGED COARSE SUBSTRATE, AND BUCKET COMPACT THE MATERIAL IN 8" LIFTS.

STEP 2: INSTALL LAYER 2 LOGS

- A. INSTALL LAYER 2 LOGS
A.1. IF EXCAVATION WAS USED TO INSTALL VERTICAL LOGS, OR THE MINIMUM PULLOUT RESISTANCE CRITERIA IN THE SPECIFICATIONS ARE NOT MET, THE FOLLOWING STEPS ARE REQUIRED:
A.1.1. ATTACH LAYER 1 AND 2 LOGS TO VERTICAL LOGS PER THE BOLTED CONNECTION DETAILS ON SHEET 15.
A.1.2. A MINIMUM OF 18 VERTICAL LOGS IN EACH LWS SHALL BE ATTACHED TO A LAYER 1 OR LAYER 2 ROOTWAD LOG.
A.1.3. EACH LAYER 1 AND LAYER 2 ROOTWAD LOG WITH A BOLTED CONNECTION SHALL HAVE A MINIMUM COARSE SUBSTRATE COVER DEPTH OF 4 FT.
B. BACKFILL LAYER 2 LOGS USING COARSE ALLUVIUM SALVAGED FROM POOL/BANK EXCAVATION. BUCKET COMPACT THE BACKFILL IN 12" LIFTS.
C. INSTALL SLASH, AND SALVAGED TREES AS DIRECTED BY THE OWNER'S REPRESENTATIVE.

STEP 3: INSTALL LAYER 3 AND LAYER 4 LOGS

- A. INSTALL LAYER 3 LOGS.
B. INSTALL SLASH AND SALVAGED TREES AS DIRECTED BY THE OWNER'S REPRESENTATIVE.
C. INSTALL LAYER 4 LOGS.
D. INSTALL SLASH, RACKING MATERIAL, AND SALVAGED TREES AS DIRECTED BY THE OWNER'S REPRESENTATIVE.
E. PLACE ADDITIONAL COARSE BACKFILL WHERE FEASIBLE. BUCKET COMPACT COARSE BACKFILL IN 12" LIFTS.

STEP 4: INSTALL LAYER 5 AND LAYER 6 LOGS

- A. INSTALL LAYER 5 LOGS.
B. INSTALL SLASH AND SALVAGED TREES AS DIRECTED BY THE OWNER'S REPRESENTATIVE.
C. PLACE ANY REMAINING COARSE BACKFILL. WORK SALVAGED FINE MATERIAL INTO TOP 12" OF BACKFILL AND LEAVE TOP 12" OF BACKFILL UNCOMPACTED.
D. INSTALL LAYER 6 LOGS.
E. CONNECT LAYER 6 LOGS TO VERTICAL LOGS AND LAYER 5 LOGS SUCH THAT EACH LAYER 6 ROOTWAD LOG HAS A MINIMUM OF 2 BOLTED CONNECTIONS. VERTICAL LOGS SHALL NOT CONTAIN MORE THAN 2 CONNECTIONS. A MINIMUM OF 18 LOG-TO-LOG CONNECTIONS IS REQUIRED FOR EACH LARGE WOOD STRUCTURE.
G. BOLTED CONNECTIONS SHALL BE SPACED A MINIMUM OF 10 FEET FROM EACH OTHER ON A SINGLE ROOTWAD LOG.
H. INSTALL ADDITIONAL SLASH AS DIRECTED BY THE OWNER'S REPRESENTATIVE.

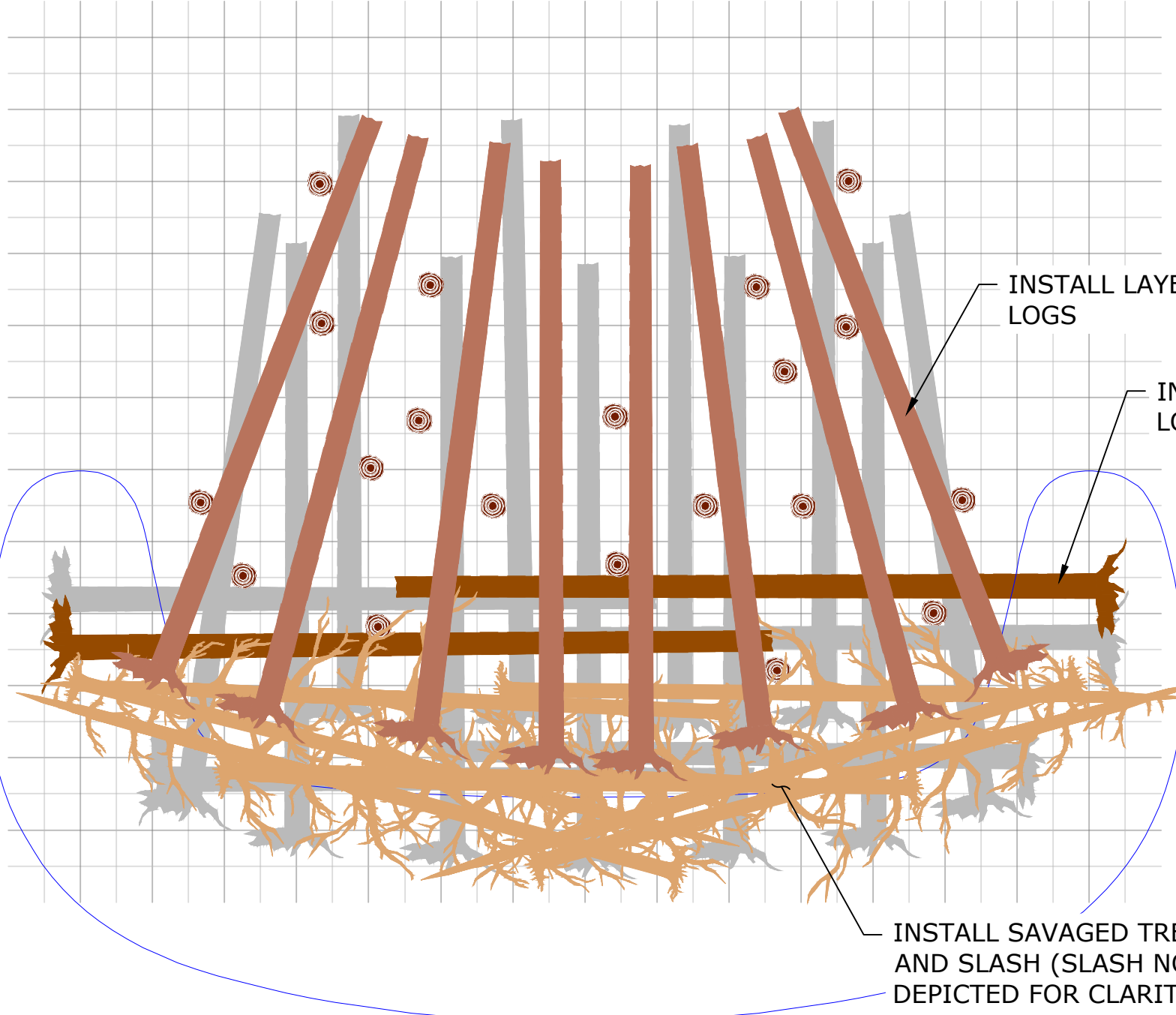

STEP 3: INSTALL LAYER 3 AND LAYER 4 LOGS

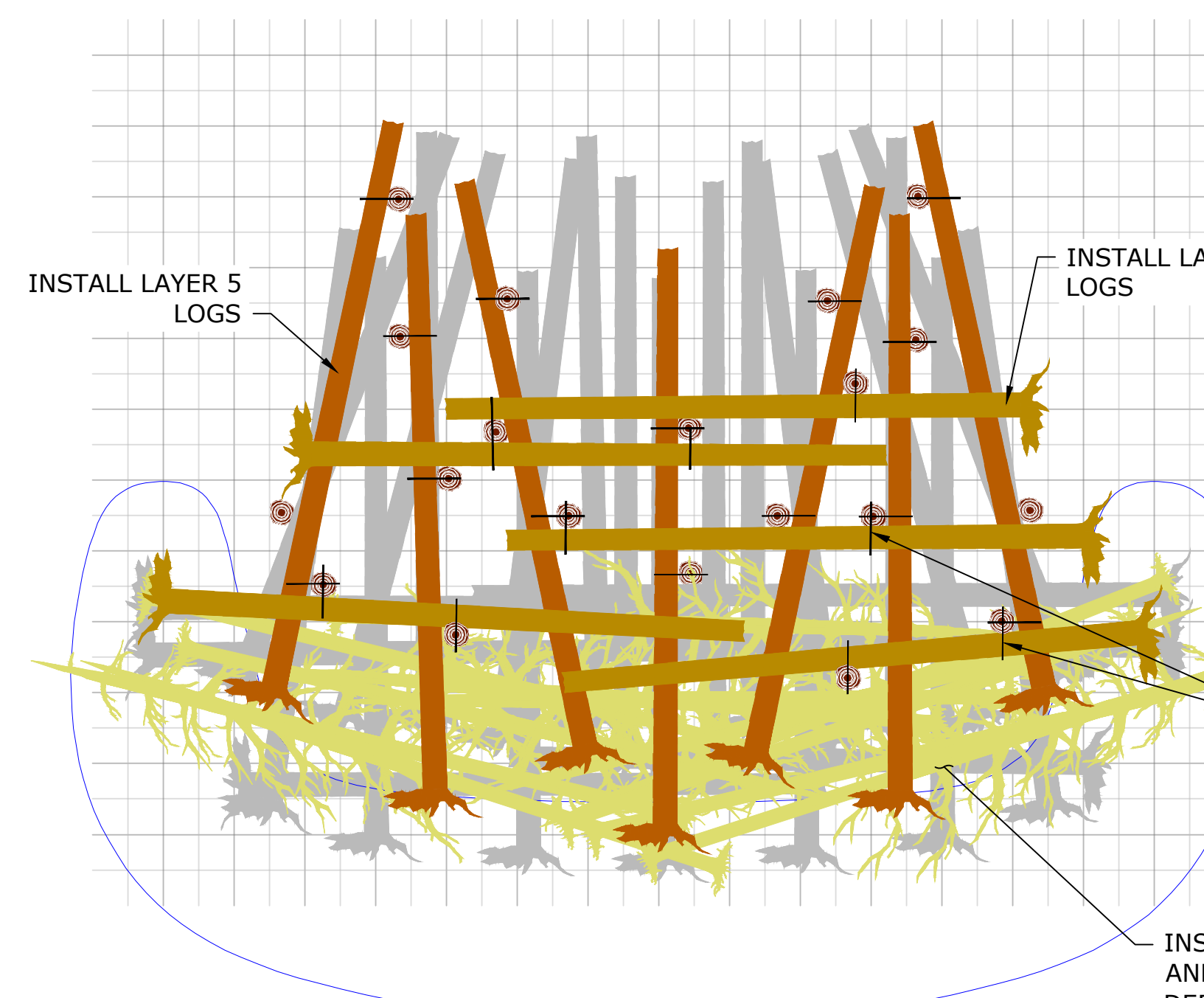

STEP 4: INSTALL LAYER 5 AND LAYER 6 LOGS

ATTACH LAYER 5 AND 6 LOGS USING BOLTED CONNECTIONS PER THE DETAILS ON SHEET 15

- LAYER 1 LOG
LAYER 2 LOG
LAYER 3 LOG
LAYER 4 LOG
LAYER 5 LOG
LAYER 6 LOG
LOG INSTALLED IN PREVIOUS STEP
VERTICAL LOG
BOLTED CONNECTION

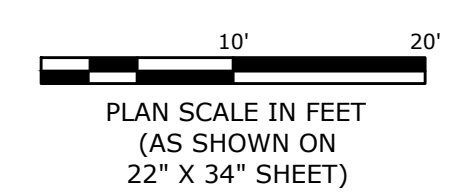

1 APEX LARGE WOOD STRUCTURE SEQUENCING 14 1"=10"

LAST SAVED DATE 2026-04-27 LWS TECH CAD DRAWN BY JFL LOWERCHIVAWA-G_DETAILS_PH2.DWG



ALWAYS THINK SAFETY
U.S. DEPARTMENT OF THE INTERIOR
BUREAU OF RECLAMATION
COLUMBIA PACIFIC NORTHWEST REGION
FCRPS HABITAT IMPROVEMENT PROGRAM
LOWER CHIVAWA RIVER PROJECT
PROJECT AREA G - PHASE 2
DRAFT FINAL DESIGN

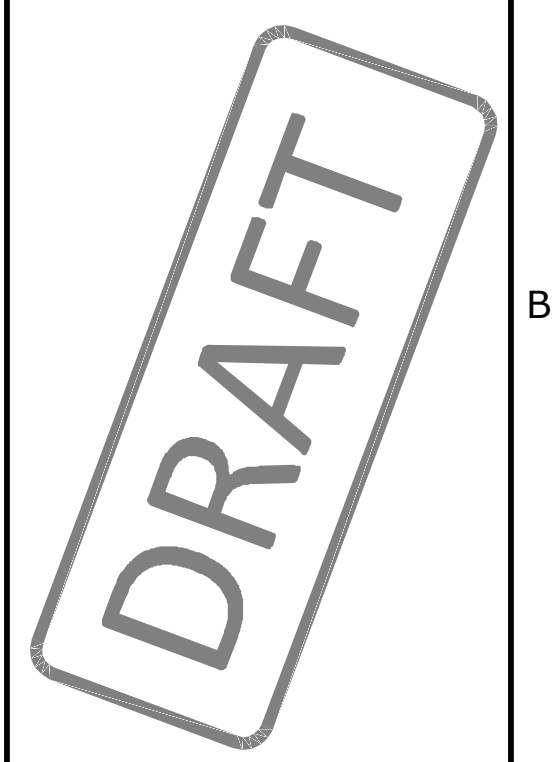

CM DRAWN
LS, PB ACCEPTED
BOISE, ID APRIL 27, 2026

TYPICAL DETAILS (3 OF 4)
SHEET 14
SHEET 14 OF 15

DRAFT

CM
DRAWN

LS, PB
ACCEPTED

BOISE, ID APRIL 27, 2026

TYPICAL DETAILS
(4 OF 4)

SHEET 15

SHEET 15 OF 15

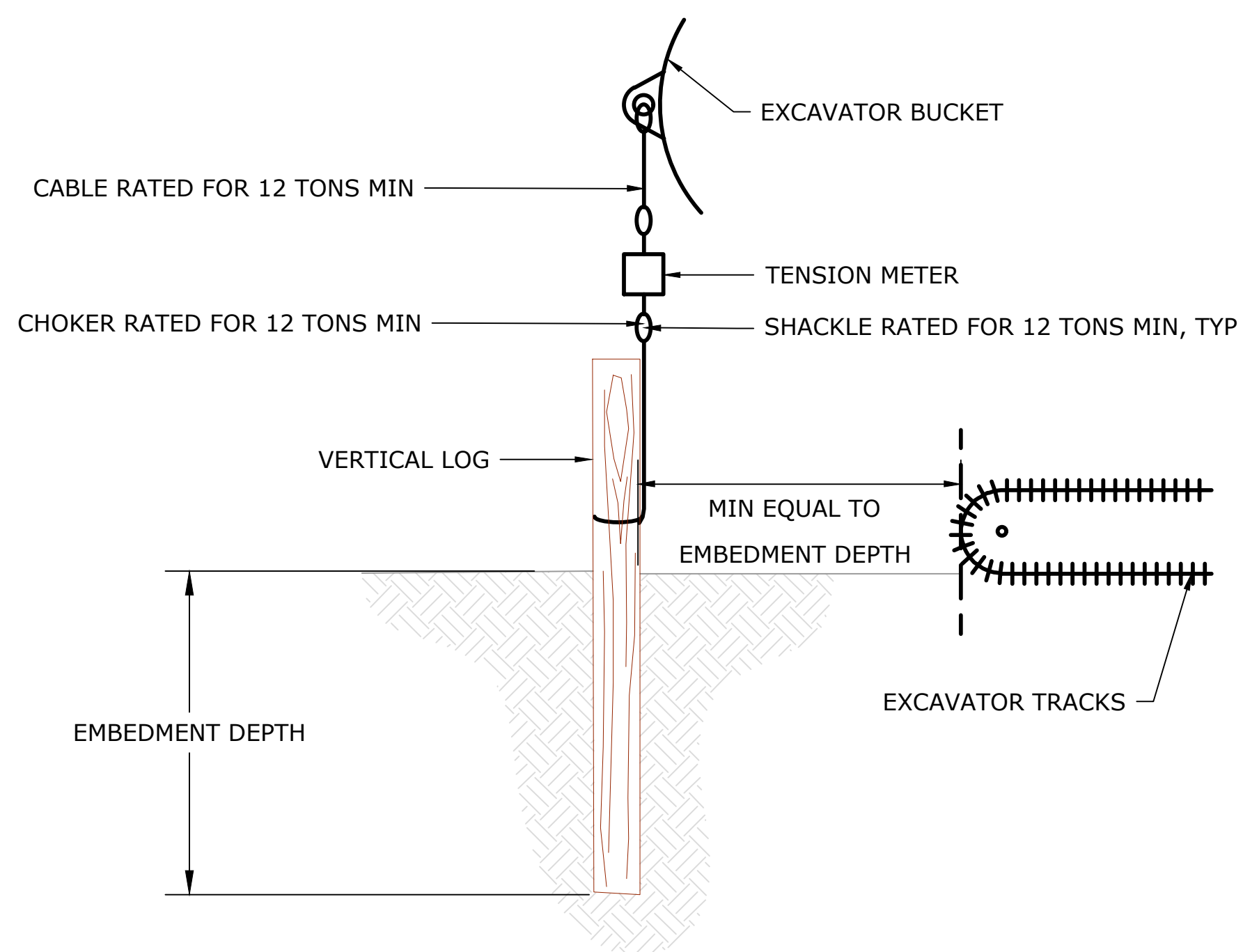

1 TYPICAL DETAIL - VERTICAL LOG TESTING
15 NOT TO SCALE

NOTES:

VERTICAL LOGS

ALL VERTICAL LOGS SHALL BE INSTALLED USING VIBRATORY PILE DRIVING EQUIPMENT. INSTALLATION BY EXCAVATION, HAMMERING, OR VIBRATORY PLATE COMPACTOR SHALL NOT BE ALLOWED.

RIGGING

RIGGING FOR VERTICAL LOG TESTING SHALL CONFORM TO THE TENSION SCALE MANUFACTURER'S RECOMMENDATIONS.

CHOKERS, CABLES AND SHACKLES SHALL HAVE MINIMUM WORKING LOAD RATING OF 12 TONS. FITTINGS SHALL BE SIZED ACCORDINGLY.

TESTING

TESTING OF VERTICAL LOGS SHALL BE PERFORMED IN THE PRESENCE OF THE OWNER'S REPRESENTATIVE.

EACH VERTICAL LOG TEST SHALL HAVE UPWARD LOAD GRADUALLY INCREASED AND AS CLOSELY ALIGNED TO AXIS OF VERTICAL LOG AS POSSIBLE. RECORD THE VERTICAL LOG DIAMETER, EMBEDMENT DEPTH AND MAXIMUM FORCE REQUIRED TO MOVE THE VERTICAL LOG. UP TO A TOTAL OF THREE LOADINGS MAY BE REQUIRED AT EACH EMBEDMENT DEPTH.

PROOF TESTS SHALL BE MADE AT UP TO FOUR EMBEDMENT DEPTHS TO BE DETERMINED IN THE FIELD. AS A GUIDELINE TEST EMBEDMENT DEPTHS MAY INCLUDE 5 FT, 6 FT, 8 FT AND 10 FT.

EXCAVATOR CONDUCTING PULL OUT LOADING SHALL BE POSITIONED NO CLOSER THAN EMBEDMENT DEPTH OF VERTICAL LOG IF POSSIBLE. IF A CLOSER POSITIONING IS REQUIRED, EXCAVATOR SHALL BE NO CLOSER THAN THAT REQUIRED TO GENERATE DESIRED LOADING WITH DISTANCE FROM VERTICAL LOG NOTED IN THE TEST RECORD. EQUIPMENT GROUND PRESSURE MAY BE REDUCED BY POSITIONING THE EXCAVATOR ACROSS HORIZONTAL LOGS, WITH DISTANCE FROM VERTICAL LOG, LOG NUMBERS AND LENGTH NOTED IN THE TEST RECORD.

PULL OUT RESISTANCE READING SHALL BE COMPARED AGAINST EXCAVATOR MAX LIFT OFFSET TABLE.

10% OF PRODUCTION VERTICAL LOGS SHALL BE PROOF TESTED TO REQUIRED LOAD. IF RESULTS VARY MORE THAN 50% THEN IT SHOULD BE ANTICIPATED THAT UP TO 25% OF THE PRODUCTION VERTICAL LOGS SHALL BE PROOF TESTED. IF THE VERTICAL LOG EMBEDMENT DEPTH DOES NOT MEET MINIMUM, OWNER'S REPRESENTATIVE MAY REQUEST ADDITIONAL PULLOUT TESTING.

CONSTRUCTED DRIVEN VERTICAL LOG EMBEDMENT DEPTH SPECIFIED IN THE DRAWINGS MAY BE REDUCED OR INCREASED, PENDING PULL OUT TEST RESULTS, AT NO ADDITIONAL COST TO THE OWNER.

VIBRATORY DRIVEN VERTICAL LOGS SHALL INCLUDE REPOSITIONING AND MODIFICATIONS OF LOG TIP AS NEEDED FOR DRIVING AS INCIDENTAL TO THE LARGE WOOD STRUCTURE.

IN THE EVENT THAT 20 MINUTES OF FULL FORCE VIBRATORY DRIVING EFFORT FAILS TO EMBED LOGS TO A SUFFICIENT DEPTH TO PROVIDE 10,000 LB OF RESISTANCE TO PULLOUT, ENGINEER SHALL DETERMINE IF VERTICAL LOGS SHALL BE REPLACED OR SUPPLEMENTED WITH ADDITIONAL STABILITY MEASURES.

STUMP-GRIND OR CHAINSAW
TOP OF LOGS TO PROVIDE A
NATURAL APPEARANCE



2 ROUGHENED TOP TYPICAL DETAIL
15

NOTES:

- VISIBLE ENDS OF VERTICAL LOGS SHALL BE ROUGHENED WITH A CHAINSAW, STUMP-GRINDER, OR OTHER SIMILAR METHOD PROVIDED THAT THE ROUGHENING DOES NOT COMPROMISE THE STRUCTURAL INTEGRITY OF THE LOG.
- UNDER NO CIRCUMSTANCES MAY THE CONTRACTOR ATTEMPT TO BREAK THE TOPS OFF OF INSTALLED VERTICAL LOGS.
- ANY VERTICAL LOGS DAMAGED OR BROKEN DURING ROUGHENING SHALL BE REPLACED AT NO ADDITIONAL COST TO THE OWNER.

PRE-DRILL HOLE A MAXIMUM
OF 1/4" OVER BOLT DIA

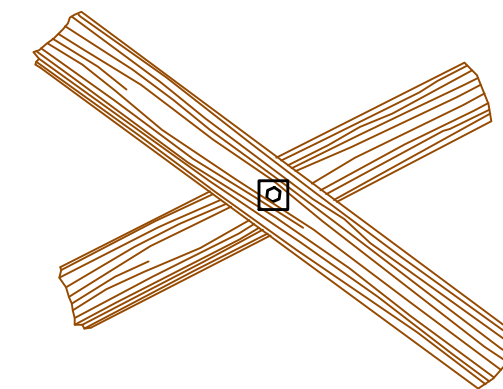

PLAN

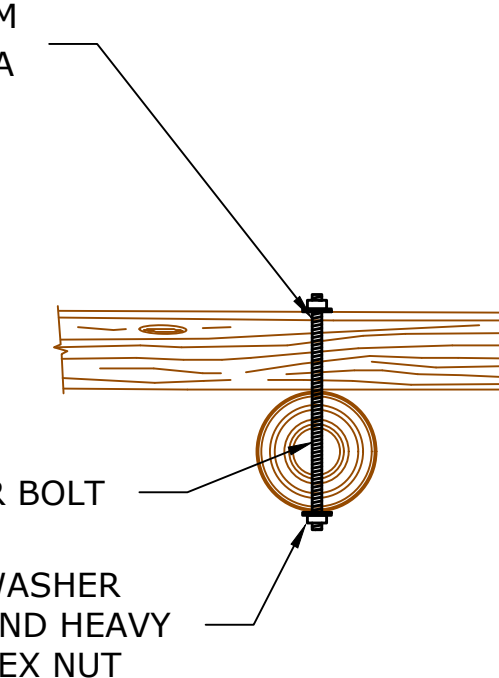

1" DIAMETER BOLT
WASHER
AND HEAVY
HEX NUT

SECTION

3 TYPICAL DETAIL - BOLTED CONNECTION
15 NOT TO SCALE

NOTES:

- BOLTS, WASHERS, AND NUTS SHALL BE IN ACCORDANCE WITH THE SPECIFICATIONS.
- DRILL 1-1/4" HOLE THROUGH LOGS.
- INSERT 1" DIAMETER THREADBAR.
- INSTALL WASHERS OVER EACH END OF THE BOLT. THREAD NUTS ONTO EACH END OF THE BOLT AND TIGHTEN THE NUT UNTIL UNDERLYING WOOD BEGINS TO CRUSH.
- IF END OF BOLT EXTENDS MORE THAN 2 INCHES BEYOND THE TIGHTENED NUT, CUT OFF EXCESS BOLT NO CLOSER THAN 1 INCH FROM THE NUT.
- PEEN END OF BOLT OR CHISEL THREADS SO NUT CANNOT BE BACKED OFF.
- FILE OR GRIND OFF SHARP EDGES ON BOLT END.